

## Minimum 70 in-lb torque

- For damper areas up to 18 sq-ft\*

## Application Methods

Medium Volume Control Dampers.

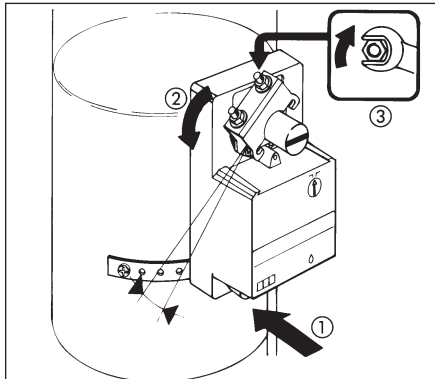

## NM Series - at a glance

		NM24 US (p. 140)	NM24-SR US (p. 142)	NM24-MFT US (p. 144)	NMQ24-MFT US (p. 146)
Torque:	70 in-lb	●	●	●	
	35 in-lb				●
Power supply:	24 VAC	●	●	●	●
Control signal:	on-off/floating point	●			
	modulating - 2 to 10 VDC		●		
	Multi-function**			●	●†
Feedback:	2 to 10 VDC		●		
	VDC variable**			●	●
Running time:	75 to 150 sec for 0 to 70 in-lb	●			
	150 sec independent of load.		●		
	Adj. 75 to 300 sec***			●	
	5 sec. constant for 95°				●
External direction of rotation switch		●	●	●	●
Angle of rotation limiting (mechanical)		●	●	●	●
External manual override		●	●	●	●
Auxiliary switches .....	(p. 148)				
General wiring .....	(p. 151)				
		Installation instructions ..(p. 149–153)			
		Start-up and checkout ..(p. 154)			

\*Based on 4 in-lb/ft<sup>2</sup> damper torque loading. Parallel blade. No edge seals. \*\*Default 2 to 10 VDC \*\*\*Default 150 seconds  
 † only VDC proportional control signal is available, and variable

## A CLOSER LOOK...



- Cut labor costs with simple direct coupling.
- Check damper position from a distance with clear position indicator.
- Don't worry about actuator burn-out. Belimo is overload-proof throughout rotation.
- Enjoy added flexibility with easy mechanical stop to adjust angle of rotation.
- Need to change control direction? Do it easily with a simple switch.
- Simple manual override button helps you get up and running faster.
- Auxiliary switch accessory (SN1,SN2) is easy to use, offers feedback or signal for additional device.
- 3 ft. plenum rated cable eases installation  
Conduit connector provided: one less detail to worry about.
- Microprocessor-controlled brushless DC motor increases actuator life span and reliability, provides constant running time independent of load. (Proportional actuators)

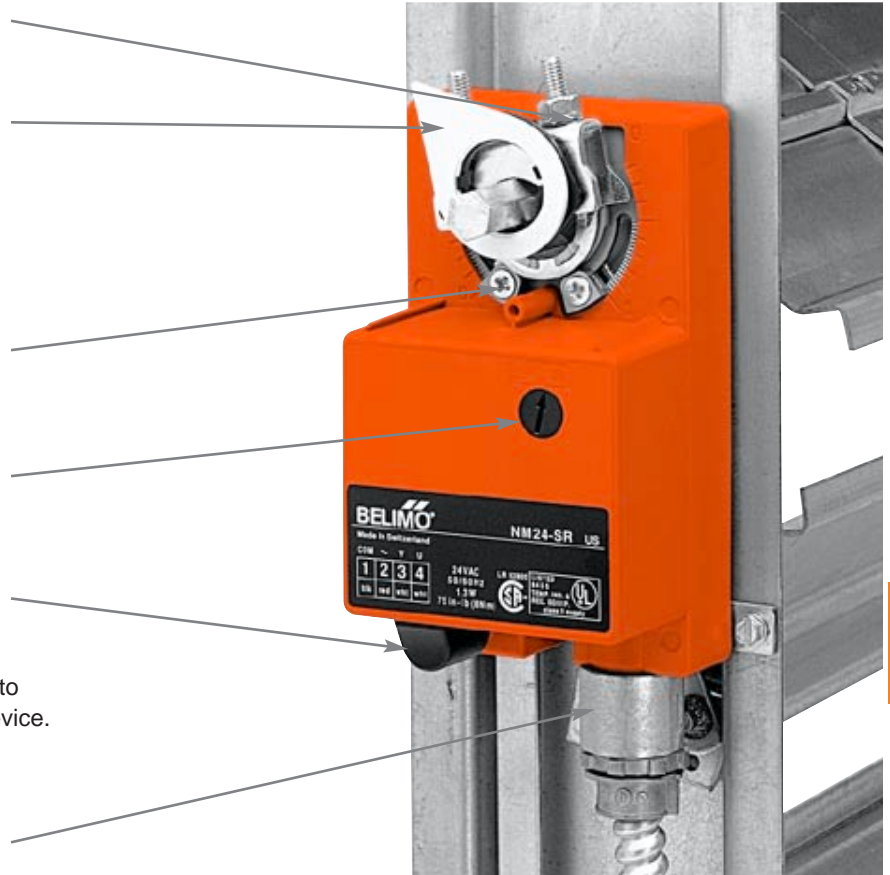

NM



## The Belimo Difference

- **Customer Commitment.**  
Extensive product range. Application assistance.  
Same-day shipments. Free technical support. Five year warranty.
- **Low Installation and Life-Cycle Cost.**  
Easy installation. Accuracy and repeatability.  
Low power consumption. No maintenance.
- **Long Service Life.**  
Components tested before assembly. Every product tested before shipment.  
30+ years direct coupled actuator design.

# NM24 US

On-off, reversible, non-spring return, direct coupled, floating point, 24 V



**Torque min. 70 in-lb, for control of air dampers surfaces up to 18 sq. ft.**

## Application

For modulating or on-off control of dampers in HVAC systems. Actual actuator sizing should be done in accordance with the damper manufacturer's specifications. Control is on-off from an auxiliary contact of a fan motor contactor, or a manual switch. The direction of rotation is reversible, for use with a floating point type control. The actuator mounts directly to the damper operating shaft with a universal V-bolt clamp assembly.

## Operation

The universal mounting bracket supplied with the actuator will prevent lateral movement of the actuator. The damper actuator is not provided with and does not require any limit switches, but is protected against overloading. The angle of rotation is mechanically limited to 95°. When reaching the damper or actuator end position, the motor stops automatically. The gears can be manually disengaged by simply pressing down the spring loaded button on the actuator cover. When this button is pressed down, the damper blades can be adjusted by hand. The position of the actuator is indicated by a visual pointer.

Auxiliary switches are easily fastened directly onto the actuator body for signalling and switching functions.

## Accessories

- AV 10-18 Damper shaft Extension
- SN1,SN2 Auxiliary switches
- ZG-H2 Actuator operator handle
- ZG-NMSA-1 Short shaft adaptor

**Note: When using NM24 US actuators, only use accessories listed on this page.**

Technical Data	NM24 US
Power supply	24 VAC ± 20% 50/60 Hz 24 VDC ± 10%
Power consumption	running: 2 W; holding: 1W
Transformer sizing	3.5 VA (Class 2 power source)
Electrical connection	3 FT, 18 GA plenum rated (UL CL2P) 1/2 in. conduit connector
Overload protection	electronic throughout 0 to 95° rotation
Angle of rotation	0 to 95°, adjust with mechanical stops
Torque	min 70 in-lb [8 Nm]
Damper area (Note 1)	18 Sq Ft
Direction of rotation	reversible with switch L/R
Position indication	clip-on indicator
Manual override	button on actuator
Running time	75 to 150 sec for 0 to 75 in-lb [0 to 8Nm] (0 to 90°)
Humidity	5 to 95% RH, non-condensing
Ambient temperature	-4°F to +122°F [-20°C to +50°C]
Storage temperature	-40°F to +176°F [-40°C to +80°C]
Housing	NEMA type 2
Housing material	UL 94-5V (flammability rating)
Agency listings	UL 873 listed, CSA C22.2 No.24 certified, CE
Noise level	less than 35 db (A)
Servicing	maintenance free
Quality Standard	ISO 9001
Weight	1.8 lbs [0.8 kg]

**Note 1** Damper area is calculated using approximately 4 in-lb/sq ft of damper area. This is an average torque requirement for good quality dampers operating under a 1" WC pressure drop. Check damper specifications for exact torque requirements.

## Dimensions [All numbers in brackets are in millimeters.]

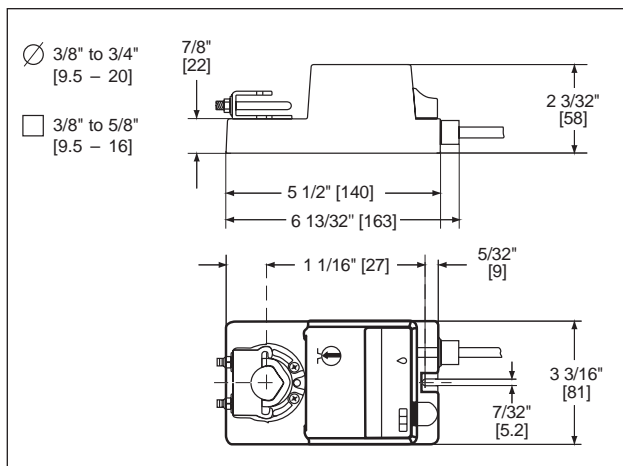

G20492-IG-Subject to change. © Belimo Aircontrols (USA), Inc.

D016

## Wiring Diagrams

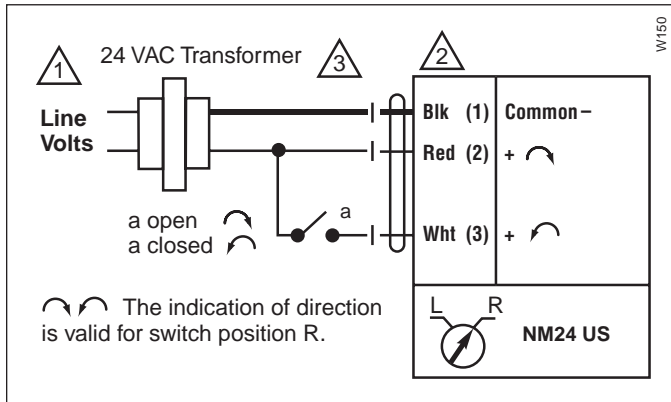

**On-Off control of NM24 US**

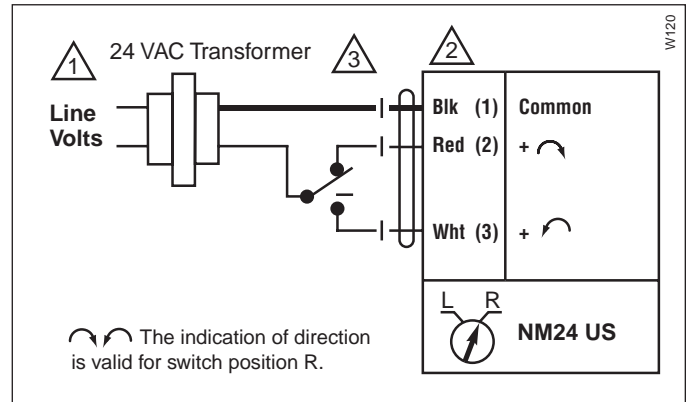

**Tri-State control of NM24 US**

### Notes:

- ① Provide overload protection and disconnect as required.
- ② Actuators are provided with color coded wires. Wire numbers are provided for reference.
- ③ May also be powered by 24 VDC.

### Bulk packaging - NM24.1 US

The bulk packaging option for the NM... series has been discontinued as of October 2003

### T-Type bracket

These are included in the single-actuator packages.

**Part # 11333 (1 piece)**

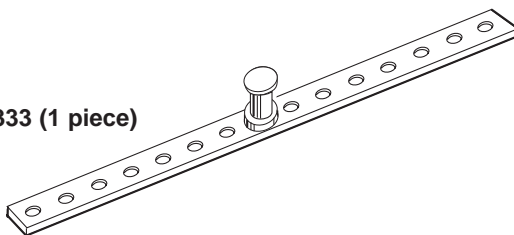

**L-Type bracket 21731**

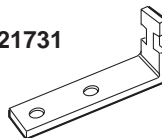

**Part #: 12503-00001 (24 pieces)**  
(includes 21731) shipped separately upon request.

### NM24 US - Typical Specification:

Control damper actuators shall be electronic direct coupled type which require no crank arm and linkage. Actuators shall be UL and CSA listed, have a 5 year warranty, and be manufactured under ISO 9001 International Quality Control Standards. Actuators shall have reversing switch and manual override on the cover, and be protected from overload at all angles of rotation. Actuators shall be as manufactured by Belimo.

# NM24-SR US



Proportional damper actuator, non-spring return, direct coupled, 24 V, for 2 to 10 VDC and 4 to 20 mA control signal

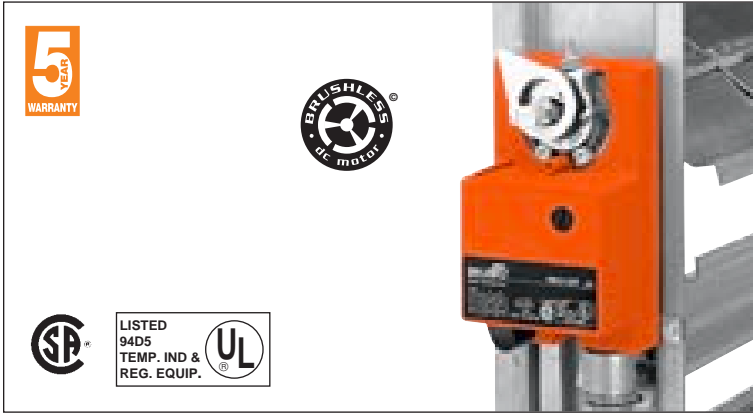

Technical Data	NM24-SR US
Power supply	24 VAC, ± 20%, 50/60 Hz 24 VDC, ±10%
Power consumption	running: 1.3 W; holding: 0.5W
Transformer sizing	3.5 VA (Class 2 power source)
Operating range Y	2 to 10 VDC, 4 to 20 mA
Input impedance	100kΩ (0.1 mA), 500Ω
Feedback output 'U'	2 to 10 VDC, 0.7 mA max
Electrical connection	3 ft, 18 GA plenum rated (UL CL2P) cable, 1/2" conduit connector
Overload protection	electronic throughout 0 to 95° rotation
Torque (Note 1)	min 70 in-lb (8 Nm)
Damper area (Note 2)	18 sq ft
Direction of rotation	reversible with Switch L/R L = CW with an increase in voltage R = CCW with an increase in voltage
Position indication	clip on indicator
Manual override	button on actuator
Angle of rotation	0 to 95°, adjust with mechanical stops
Running time (35-95°)	150 seconds independent of max. angle of rotation or torque
Running time (0-35°)	0 to 150 seconds proportional to max. angle of rotation (Note 3)
Run time stability	± 5%
Humidity	5 to 95% RH, non-condensing
Ambient temperature	-4 to +122° F (-20 to +50° C)
Storage temperature	-40 to +176° F (-40 to +80° C)
Mounting position	not sensitive to position
Housing	NEMA 2
Housing material	UL 94-5V (flammability rating)
Noise level	less than 35 dB (A)
Agency listings	UL 873 listed, CSA C22.2 No.24 certified, CE
Quality standard	ISO 9001
Servicing	maintenance free
Weight	1.8 lbs. (0.8kg.)

- Note 1** Minimum torque is produced at minimum voltage, minimum temperature.
- Note 2** Damper area is calculated using approximately 4 in-lb/sq ft of damper area. This is an average torque requirement for good quality dampers operating under a 1" WC pressure drop. Check damper specifications for exact torque requirements.
- Note 3** The on board microprocessor measures the actuators full stroke on startup. It then adjusts the actuator speed to ensure 150 second run time for 35°-95°. Below 35° stroke, the speed is constant and run time varies with rotation angle.

**Torque min. 70 in-lb, for control of air dampers surfaces up to 18 sq. ft.**

## Application

For proportional modulation of dampers in HVAC systems. Actual actuator sizing should be done in accordance with the damper manufacturer's specifications. The actuator mounts directly to the damper operating shaft with a universal V-bolt clamp assembly.

## Operation

The actuator operates in response to a 2 to 10 VDC, 2 to 10 V phasecut or, with the addition of a 500Ω resistor, a 4 to 20 mA control input from an electronic controller or positioner. A 2 to 10 VDC feedback signal is provided for position indication or master-slave applications. A built-in microprocessor automatically tests for the amount of rotation required to modulate the damper fully closed to fully open. The actuator will self-adjust to run at a consistent running time of 150 seconds, and rescale the input signal so the entire 8 volt control range is used to provide maximum resolution of the control system. The microprocessor will also correct for compression of tight close-off gaskets with age, providing the actuator is not on its mechanical stops. A functional test of the actuator-damper assembly may be done by pressing in the manual override button, this will activate the actuators test mode and cycle the actuator fully open and closed. A 2 to 10 VDC feedback (U) is provided with full 8 volt output range proportional to the operational rotation of the damper.

A digital rotation sensing circuit protects the actuator in a stall anywhere in its 95° working range without the need of limit switches.

Auxiliary switches are easily fastened directly onto the actuator body for signalling and switching functions.

## Accessories

- AV 10-18 Damper shaft extension
- SN1,SN2 Auxiliary switches
- ZG-H2 Actuator operator handle
- ZG-NMSA-1 Shaft adaptor for short shafts

**Note: When using NM24-SR US actuators, only use accessories listed on this page.**

## Dimensions [All numbers in brackets are in millimeters.]

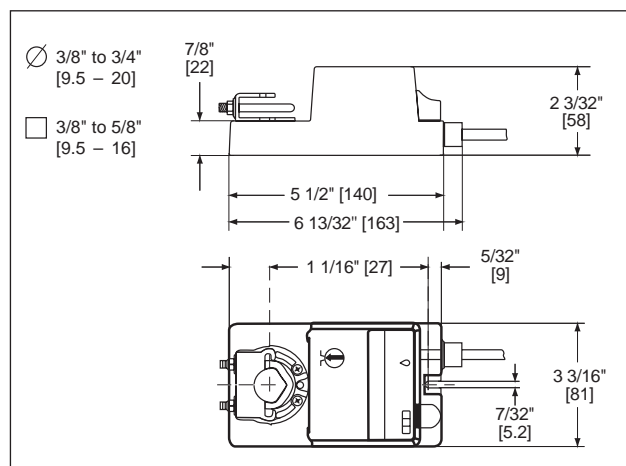

Proportional damper actuator, non-spring return, direct coupled, 24 V, for 2 to 10 VDC and 4 to 20 mA control signal

## Wiring diagrams

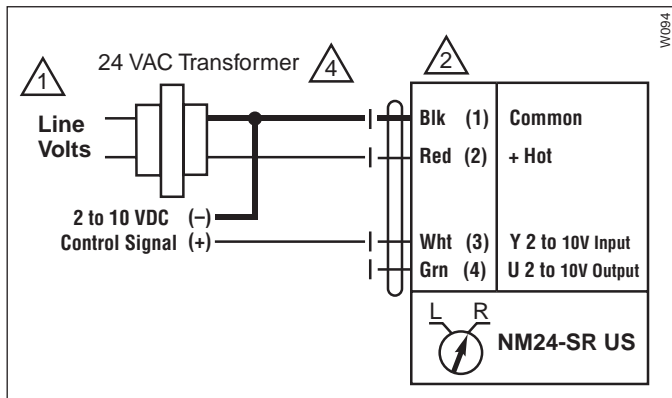

2 to 10 VDC control of NM24-SR US

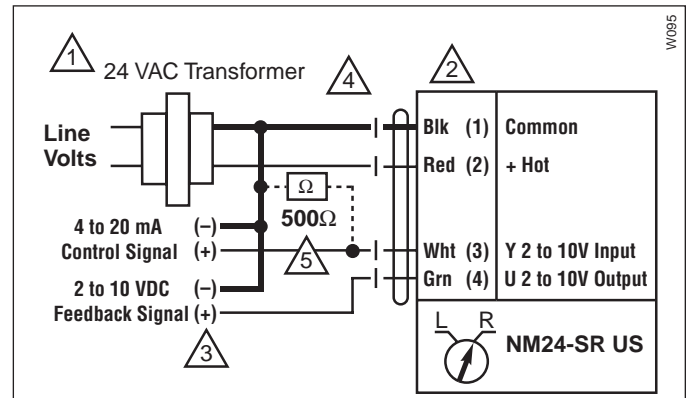

4 to 20 mA control of NM24-SR US with 2 to 10 VDC feedback output

### Notes:

- 1 Provide overload protection and disconnect as required.
- 2 Actuators are provided with color coded wires. Wire numbers are provided for reference.
- 3 Connect actuator common (Wire 1) to Negative (-) leg of control circuits only.
- 4 May also be powered by 24 VDC.
- 5 The 500Ω resistor converts the 4 to 20 mA control signal to 2 to 10 VDC.

### Bulk packaging - NM24-SR.1 US

The bulk packaging option for the NM... series has been discontinued since October 2003

### T-Type bracket

These are included in the single-actuator packages.

Part # 11533 (1 piece)

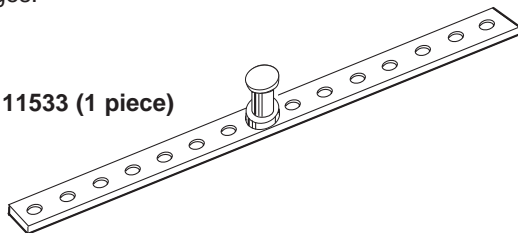

L-Type bracket 21731

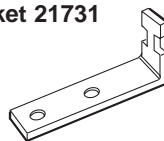

Part #: 12503-00001 (24 pieces)  
(includes 21731) shipped separately upon request.

### Typical Specification:

Control damper actuators shall be electronic direct coupled type which require no crank arm and linkage. Actuators shall be UL and CSA listed, have a 5 year warranty, and be manufactured under ISO 9001 International Quality Control Standards. Actuators shall have reversing switch and gear disengagement button on the cover, and be electronically protected from overload at all angles of rotation. Actuators shall respond to 2 to 10VDC output relative to position regardless of the amount of damper rotation. Actuators shall have brushless DC motor. Run time shall be constant and independent of torque and angular rotation between 35° and 95°. A 2 to 10 VDC feedback signal shall be provided for position indication or master-slave applications. Actuators shall be as manufactured by Belimo.

# NM24-MFT US

Proportional damper actuator, non-spring return, Multi-Function Technology®

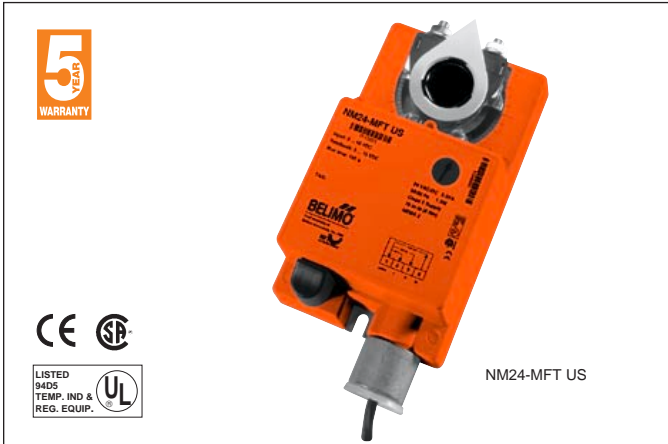

- Torque min. 70 in-lb
- Control 2 to 10 VDC (DEFAULT)
- Feedback 2 to 10 VDC (DEFAULT)

### Application

For proportional modulation of dampers in HVAC systems. The NM24-MFT US is a non-spring return type actuator. When supply power is removed the actuator will maintain its last position.

### Default/Configuration

The default parameters for 2 to 10 VDC applications of the NM24-MFT US actuator are assigned during manufacturing. If necessary, custom versions of the actuators can be ordered. The parameters noted in the Technical Data table are variable.

These parameters can be changed by three means:

- Pre-set configurations from Belimo
- Custom configurations from Belimo
- Configurations set by the customer using the MFT-Handy® or the MFT-Actuate™ PC software application.

### Operation

The NM24-MFT US actuator provides 95° of rotation and is provided with a position indicator. The actuator will synchronize its mechanical stop or the damper or valves mechanical stop and use this point for its zero position during normal control operations.

The actuator uses a brushless DC motor which is controlled by an Application Specific Integrated Circuit (ASIC) and a micro-processor. The microprocessor provides the intelligence to the ASIC to provide a constant rotation rate and to know the actuator's exact position. The ASIC monitors and controls the brushless DC motor's rotation and provides a Digital Rotation Sensing (DRS) function to prevent damage to the actuator in a stall condition. The position feedback signal is generated without the need for mechanical feedback potentiometers using DRS. The actuator may be stalled anywhere in its normal rotation without the need of mechanical end switches.

The NM24-MFT US is mounted directly to control shafts up to 3/4" diameter by means of its universal clamp and anti-rotation bracket. The actuator provides constant torque to the application with and without power applied to the actuator. The NM24-MFT US actuator is shipped in a Mid position, compression against seats or gaskets for tight shut-off is accomplished manually.

Technical Data	NM24-MFT US
Power supply	24 VAC, ± 20%, 50/60 Hz 24 VDC, ±10%
Power consumption	running: 1.3W; holding: 0.5W
Transformer sizing	3.5 VA (Class 2 power source)
Electrical connection	3 ft, 18 GA, plenum cable, 1/2" conduit connector
Overload protection	electronic throughout 0 to 95° rotation
Operating range Y*	2 to 10 VDC, 4 to 20 mA (w/500 Ω, 1/4 W resistor) ZG-R01
Input impedance	100kΩ for 2 to 10 VDC (0.1 mA) 500Ω for 4 to 20 mA 1500Ω for PWM, Floating point and On-Off control
Feedback output U*	2 to 10 VDC, 0.5 mA max
Torque*	min 70 in-lb (8 Nm)
Direction of rotation*	reversible with switch CW/CCW CW=CW with decrease in signal CCW=CCW with a decrease in signal
Angle of rotation*	0 to 95°, adjust with mechanical stops
Running time*	150 seconds constant
Angle of Rotation Adaptation*	Off (Default)
Override control*	Min. (Min Position) = 0% ZS (Mid. Position) = 50% Max. (Max. Position) = 100%
Manual override	Manual push button
Position indication	clip on indicator
Humidity	5 to 95% RH, non-condensing
Ambient temperature	-4 to +122° F (-20 to +50° C)
Storage temperature	-40 to +176° F (-40 to +80° C)
Housing	NEMA 2, IP54
Housing material	UL 94-5V (flammability rating)
Noise level	less than 35 dB (A)
Agency listings	UL 873 listed, CE, CSA C22.2
No .24 certified	
Quality standard	ISO 9001
Servicing	maintenance free
Weight	1.8 lbs. (0.8kg.)

\* Variable when configured with MFT options

### Dimensions [All numbers in brackets are in millimeters.]

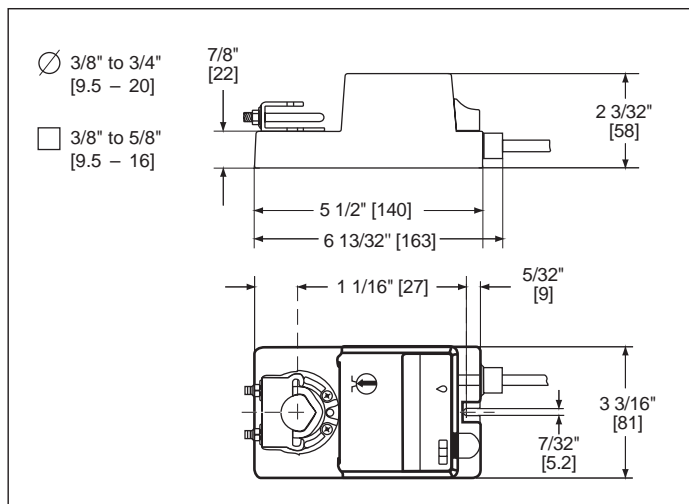

G20492-IG-Subject to change. © Belimo Aircontrols (USA), Inc.

D016

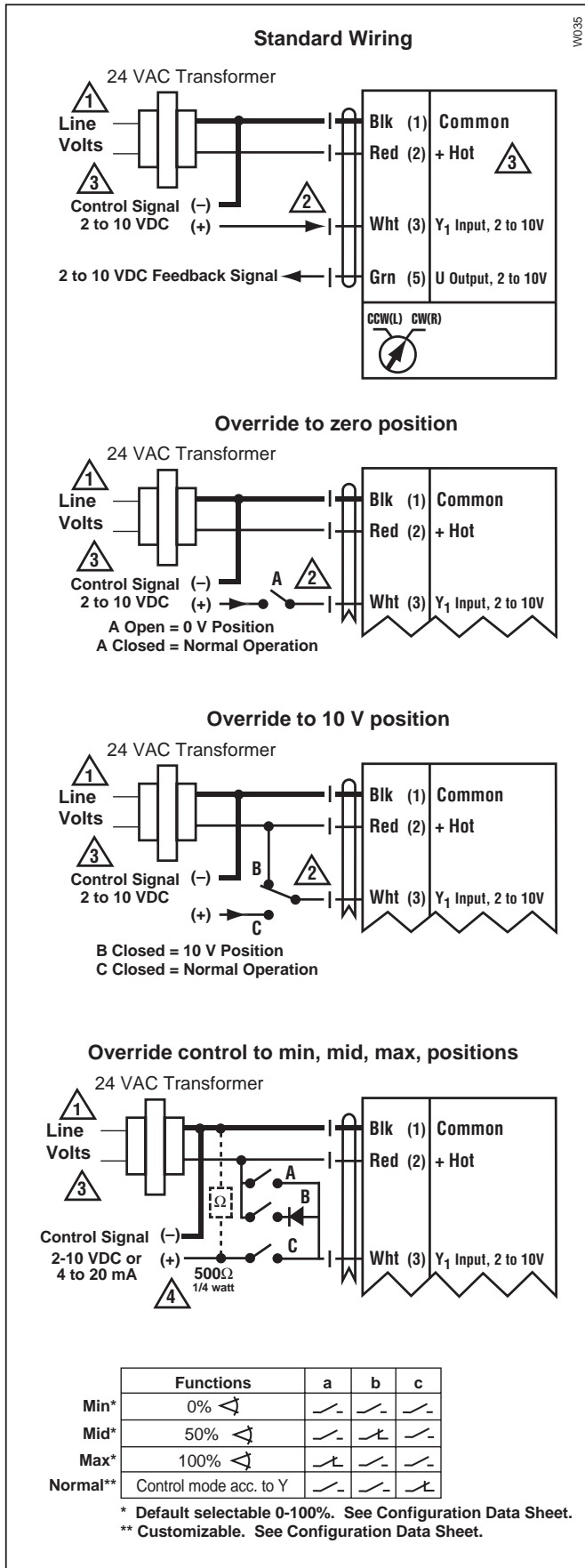

2 to 10 VDC Control Signal

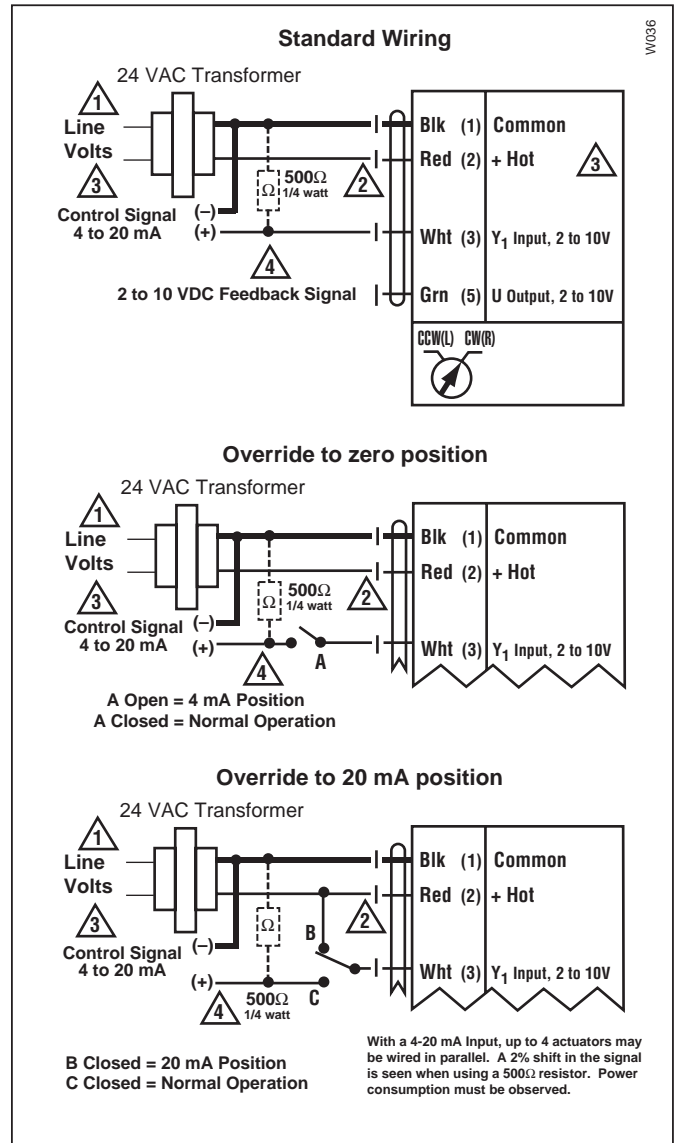

4 to 20 mA Control Signal

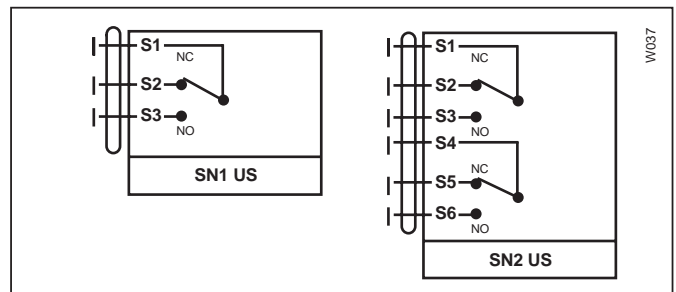

SN... Auxiliary Switches for NM24-MFT US

**Notes**

- Provide overload protection and disconnect as required.
- Actuators may be connected in parallel if not mechanically mounted to the same shaft. Power consumption and input impedance must be observed.
- Actuator may also be powered by 24 VDC.
- ZG-R01 may be used.



# NMQ24-MFT US

Fast acting, proportional damper actuator, non-spring return, Multi-Function Technology®

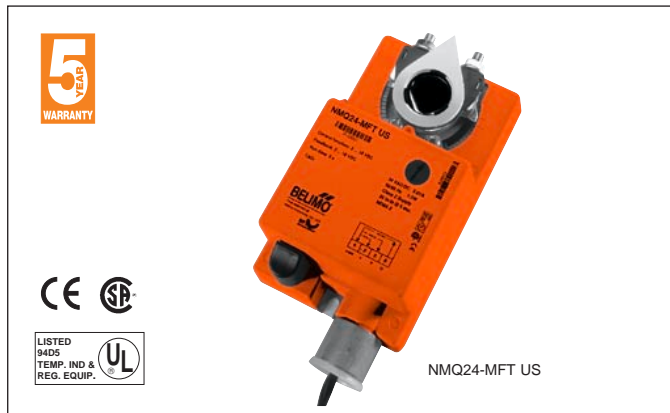

- Torque min. 35 in-lb
- Running time 5.0 to 8.0 seconds (5 sec. DEFAULT)
- Control 2 to 10 VDC (DEFAULT)
- Feedback 2 to 10 VDC (DEFAULT)

## Application

For proportional modulation of dampers in HVAC systems with fast running requirements, or some Laboratory fume hoods. The NMQ24-MFT US is a non-spring return type actuator. When supply power is removed the actuator will maintain its last position.

## Default/Configuration

The default parameters for 2 to 10 VDC applications of the NMQ24-MFT US actuator are assigned during manufacturing. If necessary, custom versions of the actuators can be ordered. The parameters noted in the Technical Data table are variable.

**These parameters can only be changed by pre-set configurations from Belimo.**

## Operation

The NMQ24-MFT US actuator provides 95° of rotation and is provided with a position indicator. Upon installation and wiring the manual override push button must be pressed twice, so the actuator will perform an adaptation and use the new mechanical points for zero position during normal control operations.

The actuator uses a brushless DC motor which is controlled by an Application Specific Integrated Circuit (ASIC) and a microprocessor. The microprocessor provides the intelligence to the ASIC to provide a constant rotation rate and to know the actuator's exact position. The ASIC monitors and controls the brushless DC motor's rotation and provides a Digital Rotation Sensing (DRS) function to prevent damage to the actuator in a stall condition. The position feedback signal is generated without the need for mechanical feedback potentiometers using DRS. The actuator may be stalled anywhere in its normal rotation without the need of mechanical end switches.

## Installation

The NMQ24-MFT US is mounted directly to control shafts up to 3/4" diameter by means of its universal clamp and anti-rotation bracket. The actuator provides constant torque to the application with and without power applied to the actuator. The NMQ24-MFT US actuator is shipped in a Mid position, compression against seats or gaskets for tight shut-off is accomplished manually.

After mounting and completing electrical installation the NMQ24-MFT US must have the adaptation function initiated. This is accomplished by pressing the manual override consecutively two times within four seconds.

Technical Data	NMQ24-MFT US
Power supply	24 VAC, ± 5%, 50/60 Hz 24 VDC, ± 5%
Power consumption	running: 9 W; holding: 1.2 W
Transformer sizing	12 VA (Class 2 power source)
Electrical connection	3 ft, 18 GA, plenum cable, 1/2" conduit connector
Overload protection	electronic throughout 0 to 95° rotation
Operating range Y*†	2 to 10 VDC, 4 to 20 mA (w/500 Ω, 1/4 W resistor) ZG-R01
Control resolution	Response sensitivity, 80 mV Reverse sensitivity, 80 mV Sensitivity when driving off mechanical position, 140 mV
Input impedance	100kΩ for 2 to 10 VDC (0.1 mA) 500Ω for 4 to 20 mA
Feedback output U*	2 to 10 VDC, 0.5 mA max
Torque*	min 35 in-lb (4 Nm)
Direction of rotation*	reversible with switch L/R L=CW with increase in signal R=CCW with a increase in signal
Angle of rotation*	0 to 95°, adjust with mechanical stops
Running time*	5.0 seconds constant for 95° rotation
Angle of Rotation Adaptation*	On-manual (Default) when less than 95% angle
Manual override	Manual push button
Position indication	clip on indicator
Humidity	5 to 95% RH, non-condensing
Ambient temperature	-4 to +122° F (-20 to +50° C)
Storage temperature	-40 to +176° F (-40 to +80° C)
Housing	NEMA 2, IP54
Housing material	UL 94-5VB (flammability rating)
Noise level	less than 52 dB (A)
Agency listings	UL 873 listed, CE, CSA C22.2 No .24 certified
Quality standard	ISO 9001
Servicing	maintenance free
Weight	1.8 lbs. (0.8kg.)

\* Variable when configured with MFT options  
† Only VDC proportional control signal is available, and variable (eg: 0-10 VDC)

## Dimensions [All numbers in brackets are in millimeters.]

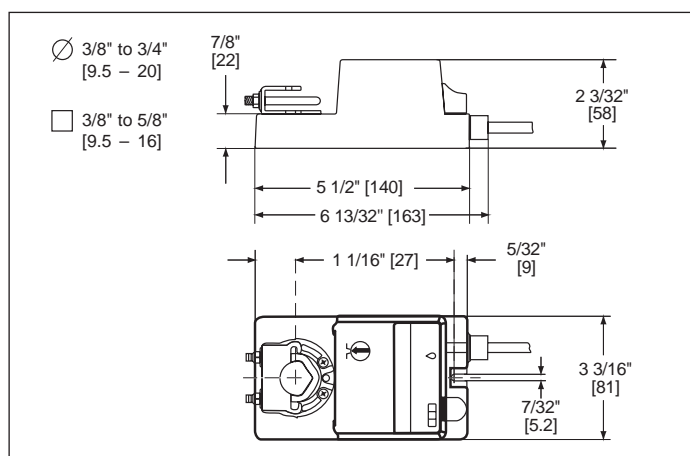

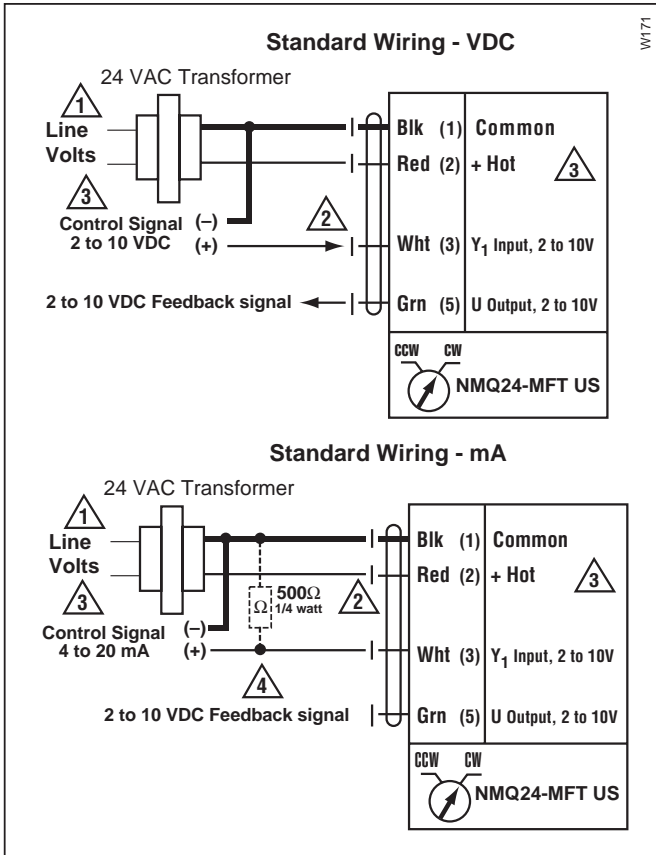

2 to 10 VDC and 4 to 20 mA Control

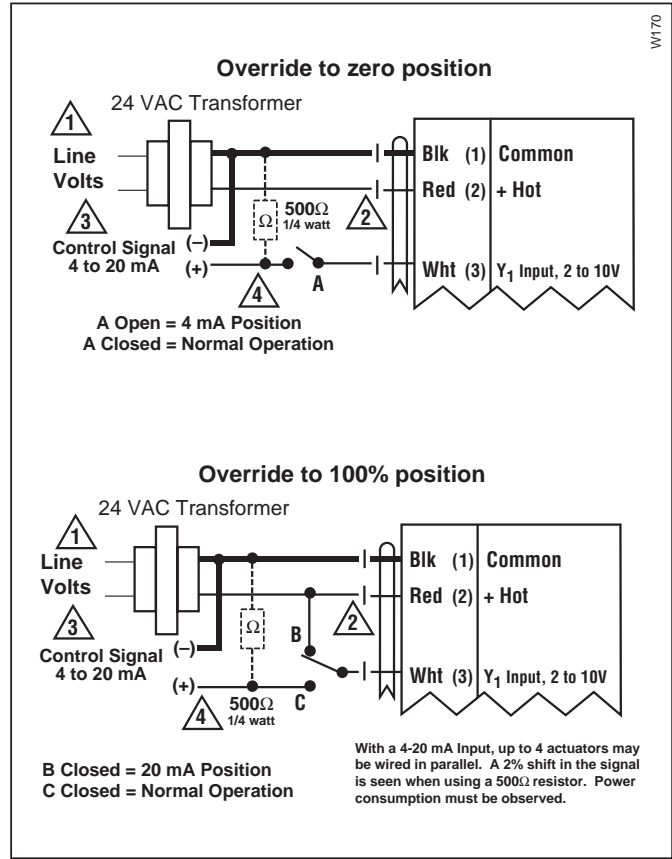

Override to open or closed position

**Response sensitivity and reverse hysteresis, for VDC applications**

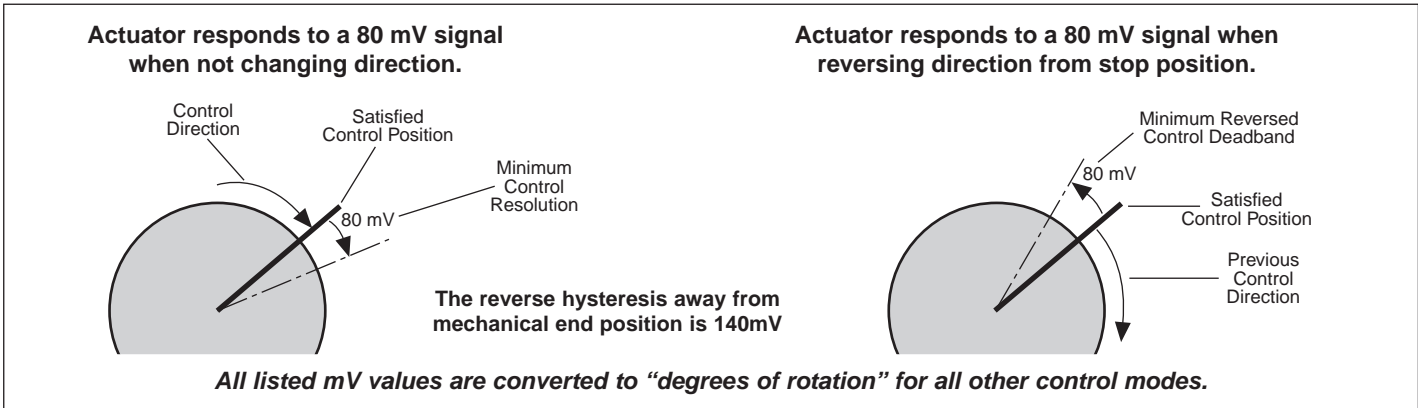

**Available configurations for the NMQ24-MFT US**

Configuration	Control		Motion	
	Input range	Position feedback	Running time	Torque
P-11001	2-10 VDC	2-10 VDC	5.0 sec	35 in-lbs
P-11002	0-10 VDC	0-10 VDC	5.0 sec	35 in-lbs
P-11003	2-10 VDC	2-10 VDC	6.0 sec	44 in-lbs
P-11004	2-10 VDC	2-10 VDC	7.0 sec	53 in-lbs
P-11005	2-10 VDC	2-10 VDC	8.0 sec	58 in-lbs
<b>Run times available up to 60 sec. @ 58 in-lbs</b>				

Start point span adjustable control input is available. Please consult Belimo for the proper configuration code. **PWM and Floating point control inputs are not available with this actuator.**

**Notes**

- 1 Provide overload protection and disconnect as required.
- 2 Actuators may be connected in parallel if not mechanically mounted to the same shaft. Power consumption and input impedance must be observed.
- 3 Actuator may also be powered by 24 VDC.
- 4 ZG-R01 may be used.

# SN1, SN2 Auxiliary Switches

For the direct coupled actuator NM 2...



Technical Data	SN1	SN2
No. of switches	1xSPDT	2xSPDT
Switching capacity	6 A (2.5A) 250 VAC	
Switching point	adjustable over full actuator rotation 0 to 10. Pre-setting with scale possible.	
Electrical connection	3 ft. 18 GA cable [1 m long 0.75mm <sup>2</sup> ]	
Humidity	5 to 95% RH non-condensing	
Ambient temperature	-22° F to +122° F [-30° C to +50° C]	
Storage temperature	-40° F to +176° F [-40° C to +80° C]	
Housing type	NEMA type 2	
Housing material rating	UL 94-V0 (flammability rating)	
Weight	4 oz [125 g]	5.6 oz [175 g]

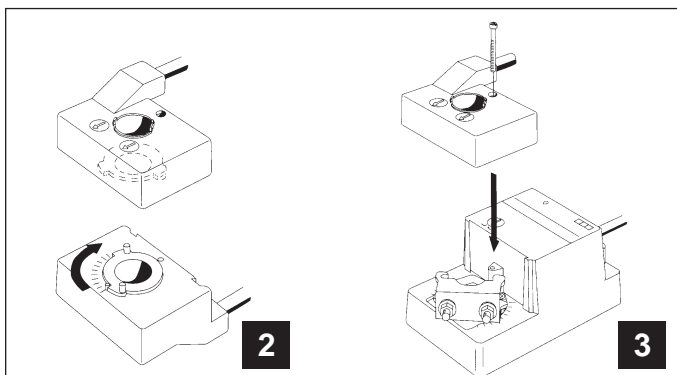
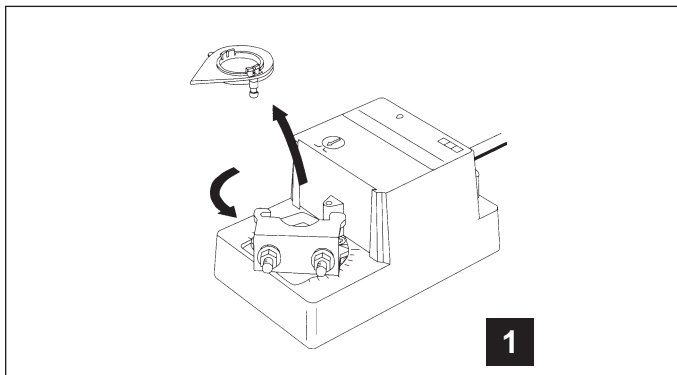

## Operation

The SN1 and SN2 auxiliary switches are used to indicate when a desired position of a damper is reached or to interface additional controls for a specific control sequence. They are modular units that mount directly onto the NM type actuators and held in place with a prefitted screw. A driver disk is attached to the actuator clamp and offers direct transmission of the actuator position to the microswitch operating cams. The switching points can be set over the full scale of 0 to 10 simply by adjusting the slotted discs.

**NOTE:** will not mount to NM actuators manufactured prior to May 1994

Voltage	Resistive	Inductive
120	6.0 A	5.0 A
250	6.0 A	2.5 A

## Wiring Diagrams

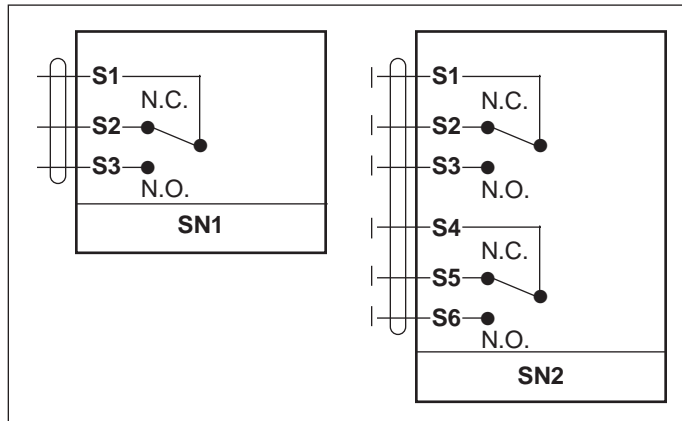

## Mounting Instructions

1. Remove pointer assembly from the actuator. Press down the manual override button and rotate the actuator fully counter-clockwise.
2. Invert SN . switch and turn the driver disk fully clockwise as indicated.
3. Slide SN . switch onto actuator and check for the correct mating of the driver disk to the universal clamp. Secure with screw.
4. Adjust switch dials as necessary.
5. Remount the white plastic pointer only onto SN . switch.

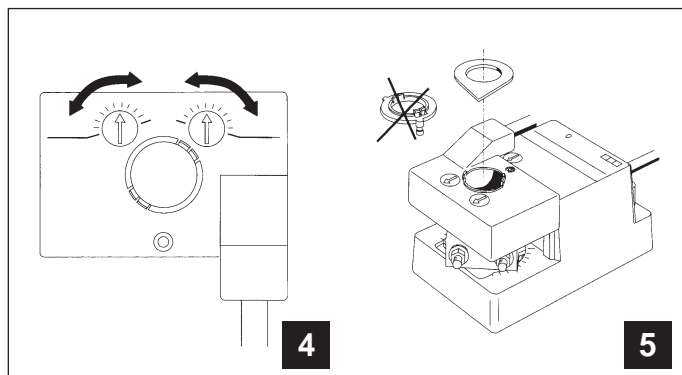

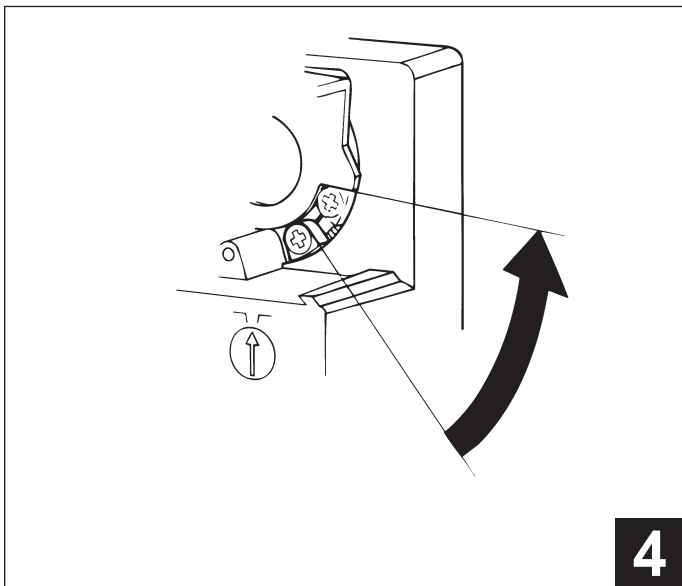
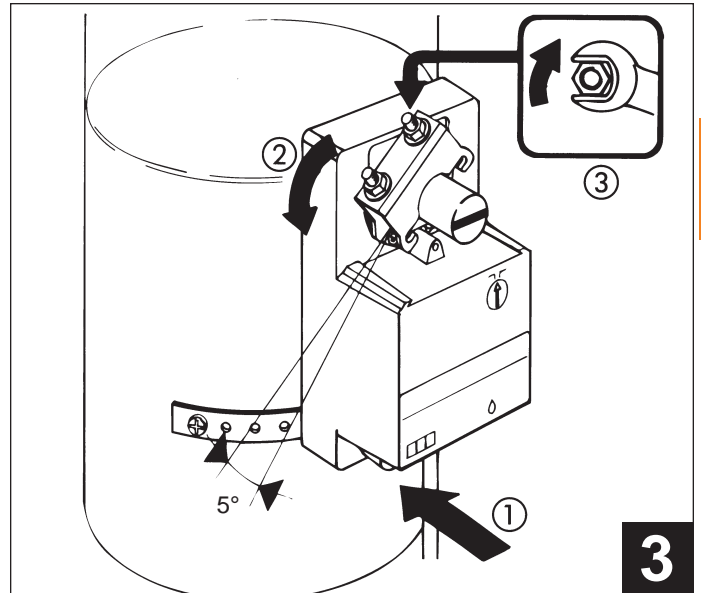
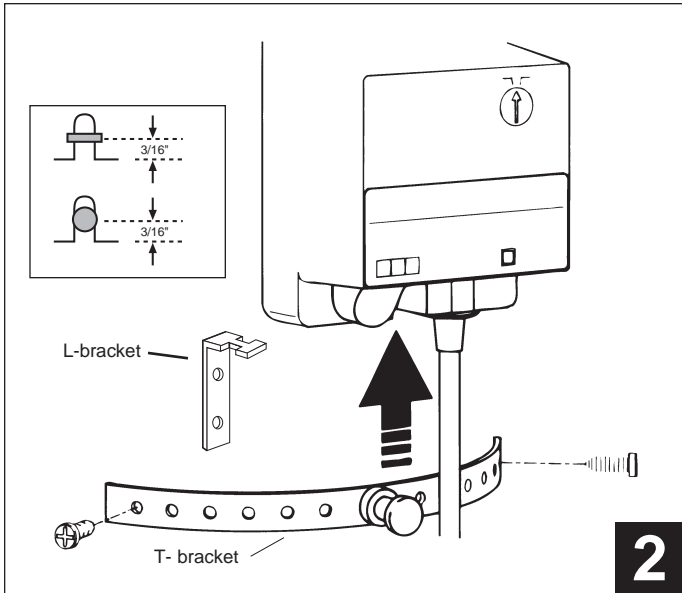
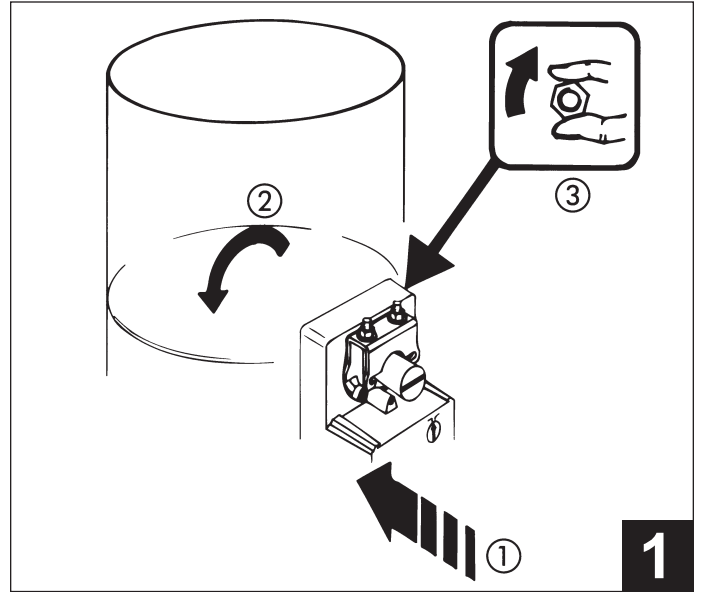
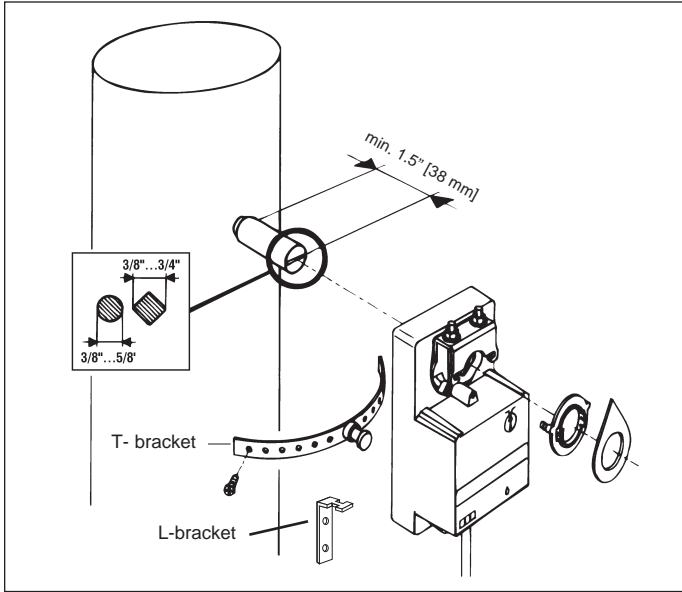

**QUICK-MOUNT VISUAL INSTRUCTIONS**

1. Turn damper blades to their fully closed position. Slide actuator onto damper shaft. Tighten the nuts on the universal clamp only finger-tight at this time.
2. Slide anti-rotation mounting strap up under actuator so that it engages actuator at the center cut-out. Secure to ductwork with self-tapping screws.
3. Loosen nuts on clamp. Press manual override button. Rotate the clamp to about 5° from the closed position (1/16 to 1/8" between stop and clamp). Tighten the two nuts on the universal clamp with a 10 mm wrench using 4 to 6 ft-lb of torque.
4. Adjust end stops, if required.
5. Mount actuator indoors. If mounted outdoors, use approved protective enclosure.

### General Information

---

#### Preliminary steps

1. Belimo actuators should be mounted indoors in a dry, relatively clean environment free from corrosive fumes. If the actuator is to be mounted outdoors, a protective enclosure must be used to shield the actuator.
2. For new construction work, **order dampers with extended shafts**. Instruct the installing contractor to allow space for mounting and service of the Belimo actuator on the shaft. The damper shaft must extend at least 2" from the duct. If the shaft extends less than 2" or if an obstruction blocks access, the shaft can be extended with the AV 10-18 shaft extension or the ZG NMSA-1 for applications with minimal mounting area.

For replacement of existing gear train actuators, it is best to mount the actuator on the damper shaft.

### Standard Mounting

---

1. Remove the plastic position indicator from the actuator. Slip the actuator's universal clamp over the damper shaft. Make sure that the bottom of the actuator (metal side) is toward the duct and the controls on the cover are accessible. Place the actuator in the desired mounting position.
2. Turn the damper shaft until the blades are fully closed.
3. Hand tighten the two nuts on the NM24 . . universal clamp.
4. Slide the stud of the anti-rotation bracket into the slot in the bottom of the actuator. Bend the strap as needed to support the rear of the actuator.
5. Fasten the strap to the duct with two screws. We recommend No. 8 self tapping sheet metal screws.
6. Loosen the two nuts on the universal clamp. Disengage the actuator gear train by pressing the "manual override button" (half round black button near the cable entry). Keeping the gears disengaged, and the damper fully closed, rotate the clamp until it is about 5° from the closed position or approximately 1/16 to 1/8 of an inch between the mechanical stop and the universal clamp.
7. Tighten the two nuts on the clamp with an 10 mm wrench (Belimo Tool-01). Use 4...6 ft-lb of torque.

The damper is now fully closed but the actuator is 5° from fully closed. This is called "pre-loading" the actuator. When the actuator is powered and sent to the closed position: it will put its

full torque on the shaft compressing the edge and blade seals. This ensures that the damper will meet its leakage rating. The actuator is electronically protected from overload and will not be damaged.

#### Adjustable stops

The adjustable stops are needed when there is no damper stop or if you want the damper to halt rotating before it reaches its stops. The NM24 . . actuator can be indefinitely stalled in any position without harm.

1. Loosen the two end stops with a No. 2 Phillips head screwdriver being careful not to unscrew the captive nut under the slot.
2. Move the stops to the desired position and re-tighten the screws.

#### Manual override

The Belimo NM24 . . actuators have a black, half round "manual override button" located next to the cable entry. Press this button and the gear train is disengaged so the damper shaft can be moved manually. Release the button and the gear train is re-engaged.

#### Testing the installation without power

1. Disengage the gear train with the manual override button and move the shaft from closed to open to closed. Ensure that there is no binding and that the damper goes fully open and closes with 5° of actuator stroke left.
2. Correct any problems and retest.

### General Wiring Instructions

**WARNING** The wiring technician must be trained and experienced with electronic circuits. Disconnect power supply before attempting any wiring connections or changes. Make all connections in accordance with wiring diagrams and follow all applicable local and national codes. Provide disconnect and overload protection as required. Use copper, twisted pair, conductors only. If using electrical conduit, the attachment must be made with flexible conduit.

**Always read the controller manufacturer's installation literature carefully before making any connections.** Follow all instructions in this literature. If you have any questions, contact the controller manufacturer and/or Belimo.

#### Transformer(s)

The NM24 type actuator requires a 24 VAC class 2 transformer and draws a maximum of 4 VA per actuator. The actuator enclosure cannot be opened in the field, there are no parts or components to be replaced or repaired.

- EMC directive: 89/336/EEC
- Software class A: Mode of operation type 1
- Low voltage directive: 73/23/EEC

**CAUTION:** It is good practice to power electronic or digital controllers from a separate power transformer than that used for actuators or other end devices. The power supply design in our actuators and other end devices use half wave rectification. Some controllers use full wave rectification. When these two different types of power supplies are connected to the same power transformer and the DC commons are connected together, a short circuit is created across one of the diodes in the full wave power supply, damaging the controller. Only use a single power transformer to power the controller and actuator if you know the controller power supply uses half wave rectification.

#### Multiple actuators, one transformer

Multiple actuators may be powered from one transformer provided the following rules are followed:

1. The TOTAL current draw of the actuators (VA rating) is less than or equal to the rating of the transformer.
2. Polarity on the secondary of the transformer is strictly followed. *This means that all No. 1 wires from all actuators are connected to the common leg on the transformer and all No 2 wires from all actuators are connected to the hotleg. Mixing wire No. 1 & 2 on one leg of the transformer will result in erratic operation or failure of the actuator and or controls.*

#### Multiple actuators, multiple transformers

Multiple actuators positioned by the same control signal may be powered from multiple transformers provided the following rules are followed:

1. The transformers are properly sized.
2. All No. 1 wires from all actuators are tied together and tied to the negative leg of the control signal. See wiring diagram.

#### Wire length for NM type actuators

Keep power wire runs below the limits listed in the Fig. 1. If more than one actuator is powered from the same wire run, divide the allowable wire length by the number of actuators to determine the maximum run to any single actuator.

Example: 3 actuators, 16 Ga wire  
 $1000 \text{ Ft} \div 3 \text{ Actuators} = 333 \text{ Ft. Maximum wire run.}$

#### Maximum wire length:

Wire Size	Max. Feet.	Wire Size	Max. Feet
12 Ga	2500 Ft.	18 Ga	600 Ft.
14 Ga	1600 Ft.	20 Ga	350 Ft
16 Ga	1000 Ft.	22 Ga	175 Ft

Fig. 1

#### Wire Type and Wire Installation Tips

For most installations, 18 or 16 Ga. cable works well with the NM24 type actuators. Use code approved wire nuts, terminal strips or solderless connectors where wires are joined. It is good practice to run control wires unspliced from the actuator to the controller. If splices are unavoidable, make sure the splice can be reached for possible maintenance. Tape and/or wire tie the splice to reduce the possibility of the splice being inadvertently pulled apart.

The NM24... proportional actuators have a digital circuit that is designed to ignore most unwanted input signals (pickup). In some situations the pickup may be severe enough to cause erratic running of the actuator. For example, a large inductive load (high voltage AC wires, motors, etc.) running near the power or control wiring may cause excessive pickup. To solve this problem, make one or more of the following changes:

1. Run the wire in metallic conduit.
2. Reroute the wiring away from the source of pickup.
3. Use shielded wire (Belden 8760 or equal). **Ground the shield to an earth ground. Do not connect it to the actuator common.**

#### Reversing switch, "L/R"

The NM24-/SR US actuators have a reversing switch on the cover labeled "L/R". With the switch in position "L", the actuator rotates clockwise with an increase in voltage or current. With the switch in Position "R", the actuator rotates counterclockwise with an increase in voltage or current.

The NM24 US, on-off, tri-state actuators when set for switch position "R", rotate clockwise when power is applied to wire #3, and counterclockwise when power is applied to wire #2.

*During checkout, the switch position can be temporarily reversed and the actuator will reverse its direction. This allows the technician a fast and easy way to check the actuator operation without having to switch wires or change settings on the thermostat. **When the check-out is complete, make sure the switch is placed back to its original position.***

### Additional Operational Information for NM24-SR US and NM24-MFT US Proportional Actuators

#### Controller types

Belimo NM24-SR US actuator is compatible with virtually all electronic controllers using a 2 to 10 VDC control signal. And will work with a 4 to 20 mA signal with the addition of a 500Ω resistor.

#### Microprocessor controlled brushless DC motor

An on board microprocessor monitors operation and controls a brushless DC motor. It also performs a self test upon power up.

#### Overload protection

The Belimo NM24-SR US actuator is protected from overload at all angles of rotation. The on board microprocessor constantly monitors the rotation of the DC drive motor inside the actuator and stops the pulses to the motor when it senses a stall condition. The DC motor remains energized and produces full rated torque to the load. This helps ensure that dampers are fully closed and that edge and blade seals are always properly compressed.

#### Brushless DC motor operation

Belimo's brushless DC motor spins by reversing the poles of stationary electromagnets housed inside rotating permanent magnets. The electromagnetic poles are switched by a microprocessor and a special ASIC (Application Specific Integrated Circuit) developed by Belimo. Unlike the conventional DC motor, there are no brushes to wear or commutators to foul.

#### Motor position detection

Belimo Brushless DC motors do not use potentiometers for positioning. Inside the motor are three "Hall Effect" sensors. These sensors detect the spinning rotor and send pulses to the microprocessor which counts the pulses and calculates the position.

#### Initialization or function check

When a power source is applied to terminal 1 and 2 the motor carries out an initialization of the actuator. If required, a function check can also be made after connection of the supply voltage by pressing in the manual override button and then releasing it. The purpose of this initialization is to determine the mechanical angle of rotation and to adapt the running time to the angle of rotation. The function check can also be used to verify that the damper, and linkage (if mounted) are running free and are correctly adjusted.

The function check makes the motor run first to the clockwise or counter-clockwise stop, depending on the selector switch position. Thereafter it runs to the opposite stop. During this operation the output (U5) supplies 2 VDC.

#### Re-initialization

Whenever the "manual override button" is pressed and released and the actuator is powered, the microprocessor will "re-initialize". See "Initialization or function check" above.

#### Motor speed and run time

The microprocessor also controls the speed of the motor. In a conventional DC motor, increased torque slows the motor speed. Since the microprocessor determines the total rotation during initialization, it can calculate how fast to turn the motor to insure a 150 second run time independent of the total rotation over a range of 35-95°. Below 35°, the motor runs at a constant speed and the run time is proportional to the angle.

#### Input Resolution

During initialization the microprocessor determines the maximum rotation angle. It then divides this angle by the working span of the input signal and calculates how many degrees to travel for each volt change in control signal or pulse length. This means that the working span (Example: 8 V for a 2 to 10 VDC Signal) is consistent for any angle of maximum rotation down to as low as 35°. This greatly simplifies engineering and checkout when dampers have differing maximum rotations.

Total Rotation	Run Time	Total Rotation	Run Time
95°	150 Sec.	35°	150 Sec.
75°	150 Sec.	15°	64 Sec.
55°	150 Sec.	5°	21 Sec.

#### Monitoring and self-adjustment of close-off position

The purpose of this function is to correct the mechanical tolerances within 4% which can change over time. It assures that the actuator always presses the damper blade with maximum pressure onto the seal. The end positions are automatically checked as soon as the actuator position comes within 3% of the total angle of rotation, at full open or full closed.

If the actuator registers a change of the end position of  $\leq 4\%$ , the angle of rotation will be modified. If the actuator registers a change of the end position  $> 4\%$ , the actuator will consider it an error and not modify the angle of rotation.

The actuator will self-adjust until it reaches its mechanical stops.

#### Initialization of NM...MFT US actuators

The non-spring return ...MFT actuators must go through an initialization procedure to learn the zero signal position. When the power is first applied to the actuator, or the gear release button is depressed, the actuator will move to its zero signal position. After the actuator learns this, it will drive to its control position.

Belimo brushless DC motors eliminate the need for potentiometers for positioning. Inside the motor are three "Hall Effect" sensors. These sensors detect the spinning rotor and send pulses to the microprocessor which counts the pulses and calculates the position to within 1/3 of a revolution of the motor.

## Control Accuracy and Stability

NM24-SR US actuators have built-in brushless DC motors which provide better accuracy and longer service life.

The NM24-SR US actuators are designed with a unique non-symmetrical deadband. The actuator follows an increasing or decreasing control signal with a 70 mV resolution. If the signal changes in the opposite direction, the actuator will not respond until the control signal changes by 70 mV. This allows these actuators to track even the slightest deviation very accurately, yet allowing the actuator to “wait” for a much larger change in control signal due to control signal instability.

### NM Actuator responds to a 70 mV signal when not changing direction from stop

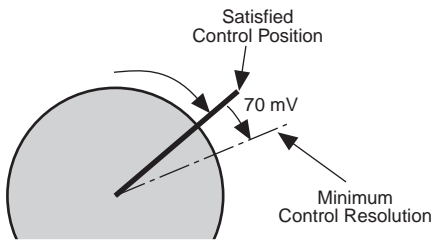

### NM Actuator responds to a 70 mV signal when reversing direction from stop position.

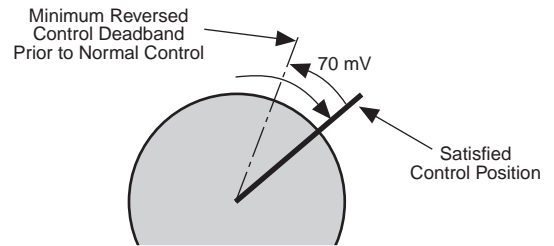

The NM24-MFT US control accuracy and stability can be found in the MFT specifications, page 187.

NM

## Additional accessories

### ZG-NMSA-1 Shaft adaptor

Used on 1/2" diameter shafts that are shorter than 3/4" and mounting space is minimal.



### SGA24/SGF24

Minimum and/or manual positioner (electronic), SGA24 is enclosed in a NEMA 4 housing. The SGF24 is for flush panel mounting.



### AV 10-18 Shaft Extension

For damper shafts 3/8 to 11/16 in [9.5 mm to 18 mm] dia or 3/8 to 9/16 in [9.5 mm to 14 mm] square.

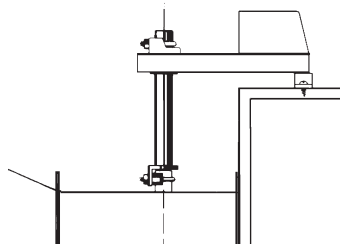

### Dimensions

[All numbers in brackets are in millimeters.]

### ZG-H2 Actuator Operator Handle

Used when it is desirable to move or adjust damper by hand. Increases leverage and precision during set-up and testing.





# Startup and Checkout



Instructions For NM24-SR US and NM24-MFT US + P-100...

## NM24-SR US and NM24-MFT US + P-100... Electrical check-out procedure

Step	Procedure	Expected Response	Actuator Responds Go To Step ...	No Response Go To Step
1.	Connect signal Input to wires 1 & 3. Connect signal output (if used) to wires 1 & 4 Connect 24 VAC/VDC power to Wires 1 & 2	Actuator drives to the "No Signal" position (usually closed), then to the "Maximum Signal" position (usually open) then to the "Control Signal" position.	Actuator operates properly <b>Step 9</b>	No response at all <b>Step 2</b> Operation is reversed <b>Step 3</b> Does not drive toward "Control Signal Position" <b>Step 4</b>
2.	Check power wiring. Correct any problems. Note 1	Power supply rating should be $\geq$ the total power requirement of the actuator(s). Minimum voltage of 19.2 VAC or 21.6 VDC.	Power wiring corrected, actuator begins to drive <b>Step 1</b>	Power wiring corrected, actuator still does not drive <b>Step 8</b>
3.	Turn reversing switch to the correct position. Make sure the switch is turned all the way left or right. Press "Override Button" all the way down and release	Actuator drives to the "No Signal" position (usually closed), then to the "Maximum Signal" position (usually open) then to the "Control Signal" position.	Actuator operates properly <b>Step 9</b>	Does not drive toward "Control Signal Position" <b>Step 4</b>
4.	Make sure the control signal positive (+) is connected to Wire No 3 and control signal negative (-) is connected to wire No. 1. Most control problems are caused by reversing these two wires. Verify that the reversing switch is all the way CCW or CW.	Drives to "Control Signal" position	Actuator operates properly <b>Step 9</b>	<b>Step 5</b>
5.	Disconnect signal input from Wires No. 1 & 3	Actuator drives to the "No Signal" position	<b>Step 6</b>	<b>Step 8</b>
6.	Check input signal with a digital volt meter (DVM). Make sure the input is within the range of the actuator. For NM24-SR this is 2 to 10 VDC or 4 to 20 mA (with 500 $\Omega$ resistor).	Input voltage or current should be $\pm 1\%$ of what controller's adjustment or programming indicate.	Controller output (actuator input) is correct. Input Polarity Correct. <b>Step 7</b>	Reprogram, adjust repair or replace controller as needed. <b>Step 7</b>
7.	Disconnect power from Wire No. 2. Reconnect signal input to Wires No. 1 & 3. Reconnect power to Wire No. 2	Actuator drives to the "No Signal" position (usually closed), then to the "Maximum Signal" position (usually open) then to the "Control Signal" position.	Actuator operates properly <b>Step 9</b>	<b>Step 8</b>
8.	Actuator does not drive	Defective actuator		Replace actuator
9.	Actuator works properly. Test controller by following controller manufacturer's instructions.			

- Note 1** Check that the transformer(s) are sized properly.
- If a common transformer is used, make sure that polarity is observed on the secondary. This means connect all No. 1 wires to one leg of the transformer and all No. 2 wires to the other leg of the transformer.
  - If multiple transformers are used with one control signal, make sure all No. 1 wires are tied together and tied to control signal negative (-).
  - Controllers and actuators must have separate 24 VAC/VDC power sources.