

Minimum 133 in-lb torque

- For damper areas up to 35 sq-ft*
(For lower torque, see NF, LF, or TF series)

Applications

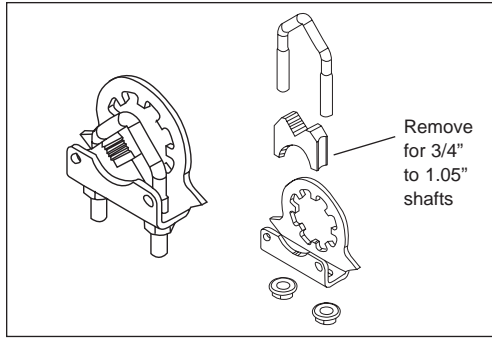

New standard clamp fits standard 1/2" shafts to 1.05" jackshafts.

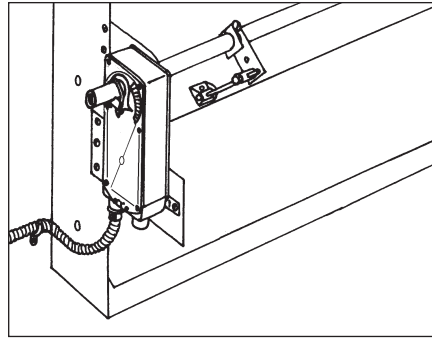

Mount directly to 1.05" jackshafts.

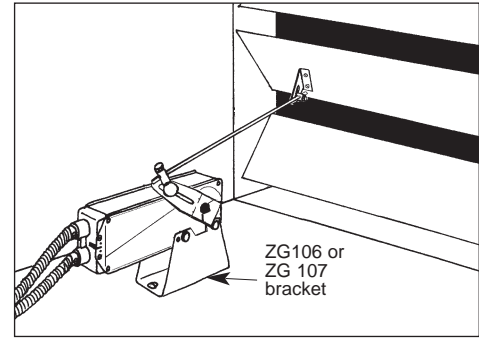

Linkage solutions are available when direct coupling is not possible. (See Mounting Methods Guide and Mechanical Accessories Documentation page 132)



All AF Actuators have BDCM

AF Series - at a glance

	AF24 US (p. 10)	AF24-S US (p. 10)	AF120 US (p. 12)	AF120-S US (p. 12)	AF230 US (p. 12)	AF230-S US (p. 12)	AF24-SR US (p. 14)	AF24-PC US (p. 16)	AF24-MFT US (p. 18)	AF24-MFT-S US (p. 18)	AF24-MFT95 US (p. 20)
Torque:	133 in-lb	●	●	●	●	●	●	●	●	●	●
Power supply :	24 VAC/DC	●	●				●	●	●	●	●
	120 VAC			●	●						
	230 VAC					●					
Control signal:	on-off	●	●	●	●	●					
	2 to 10 VDC						●				
	Multi-function**								●	●	
	0 to 135Ω										●
	0 to 20 V phasecut							●			
Feedback signal:	2 to 10 VDC						●	●			
	VDC variable**								●	●	●
Running time motor:	150 sec constant	●	●	●	●	●	●	●			
	Adj. 75 to 300 sec.***								●	●	●
	spring: <20 sec	●	●	●	●	●	●	●	●	●	●
Brushless DC Motor		●	●	●	●	●	●	●	●	●	●
External direction of rotation switch							●	●	●	●	●
Manual override		●	●	●	●	●	●	●	●	●	●
Appliance rated cable, 18 GA		●	●	●	●	●	●	●	●	●	●
Built-in auxiliary switch 2 SPDT			●	●		●				●	
Installation instructions(p. 22-27)	General wiring(p. 29)		Start-up and checkout (p. 30)								
Electrical operations(p. 28)											

*Based on 4 in-lb/ft² damper torque loading. Parallel blade. No edge seals. **Default 2 to 10 VDC. ***Default 150 seconds.

A CLOSER LOOK...



AF

- Cut labor costs with simple direct coupling.
- True mechanical spring return – the most reliable failsafe.
- Reverse mount for clockwise or counterclockwise fail-safe.
- Check damper position easily with clear position indicator.
- Overload-proof throughout rotation
- Temporary restrictions in damper movement will not change actuator operation. Actuator returns to normal operation when restriction is removed. (modulating actuators)
- Easy mechanical stop to adjust angle of rotation (add ZDB-AF2 accessory).
- By eliminating internal condensation Golden Point breather membrane optimizes performance in harsh airstream environments.
- Built-in auxiliary switch is easy to use, offers feedback or signal for additional device. (-S models)
- Manual override crank speeds installation
- Need to change control direction? Do it easily with a simple switch. (modulating actuators)
- Microprocessor-controlled brushless DC motor increases actuator life span and reliability, provides constant running time. (modulating actuators)
- Rugged metal housing withstands rough handling in the mechanical room.
- 3 ft. appliance cable and conduit connector eases installation.
- Double insulated – no need for separate safety ground. A Belimo exclusive. (-S,120V, 230V models)
- Automatically compensates for damper seal wear, ensuring tight close-off.

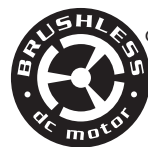

The Belimo Difference

- **Customer Commitment.**
Extensive product range. Application assistance.
Same-day shipments. Free technical support. Five year warranty.
- **Low Installation and Life-Cycle Cost.**
Easy installation. Accuracy and repeatability.
Low power consumption. No maintenance.
- **Long Service Life.**
Components tested before assembly. Every product tested before shipment.
30+ years direct coupled actuator design.

AF24 (-S) US

On-off, spring return failsafe, 24 V



Torque min. 133 in-lb, for control of air dampers

Technical Data	AF24 (-S) US
Power supply	24 VAC \pm 20% 50/60 Hz 24 VDC \pm 10%
Power consumption	running: 5 W; holding: 1.5 W
Transformer sizing	10 VA (class 2 power source)
Electrical connection	3 ft, 18 GA appliance cable 1/2" conduit connector
Electrical protection	auxiliary switches are double insulated
Overload protection	electronic throughout 0° to 95° rotation
Angle of rotation	95°, adjustable 35 to 95° w/ ZDB-AF2
Torque	133 in-lb [15 Nm] constant
Direction of rotation	reversible with CW/CCW mounting
Position indication	visual indicator, 0° to 95° (0° is spring return position)
Manual override	3mm hex crank (shipped w/actuator)
Auxiliary switches	2 x SPDT 7A (2.5A) @ 250 VAC, UL listed one set at +5°, one adjustable 25° to 85°
Running time	150 sec. constant, independent of load, spring return < 20 sec
Humidity	5 to 95% RH non-condensing
Ambient temperature	-22°F to +122°F [-30°C to +50°C]
Storage temperature	-40°F to +176°F [-40°C to +80°C]
Housing	NEMA type 2 / IP54
Housing material	zinc coated steel
Agency listings	UL 873 listed, CSA C22.2 No. 24 certified
Noise level	max. 45 dB (A)
Servicing	maintenance free
Quality standard	ISO 9001
Weight	6.0 lbs (2.7 kg.)

Application

For on-off, fail-safe control of dampers in HVAC systems. Actuator sizing should be done in accordance with the damper manufacturer's specifications. Control is on-off from an auxiliary contact, or a manual switch.

The actuator is mounted directly to a damper shaft up to 1.05" in diameter by means of its universal clamp. A crankarm and several mounting brackets are available for applications where the actuator cannot be direct coupled to the damper shaft.

Operation

The AF series actuators provide true spring return operation for reliable fail-safe application and positive close off on air tight dampers. The spring return system provides consistent torque to the damper with, and without, power applied to the actuator.

The AF series provide 95° of rotation and are provided with a graduated position indicator showing 0° to 95°. The AF has a unique manual positioning mechanism which allows the setting of any damper position within its 95° of rotation. The AF series actuators are shipped at +5° (5° from full fail-safe) to provide automatic compression against damper gaskets for tight shut-off. When power is applied to the AF series, the manual mechanism is released. The actuators will now try to close against the 0° position during its normal control operations. The manual override can also be released physically by the use of a crank supplied with the actuator.

The AF uses a brushless DC motor which is controlled by an Application Specific Integrated Circuit (ASIC). The ASIC monitors and controls the actuator's rotation and provides a digital rotation sensing function to prevent damage to the actuator in a stall condition. The actuator may be stalled anywhere in its normal rotation without the need of mechanical end switches.

The AF24-S US version is provided with 2 built in auxiliary switches. These SPDT switches are provided for safety interfacing or signaling, for example, for fan start-up. The switching function at the fail-safe position is fixed at +5°, the other switch function is adjustable between +25° to +85°.

Dimensions [All numbers in brackets are in millimeters.]

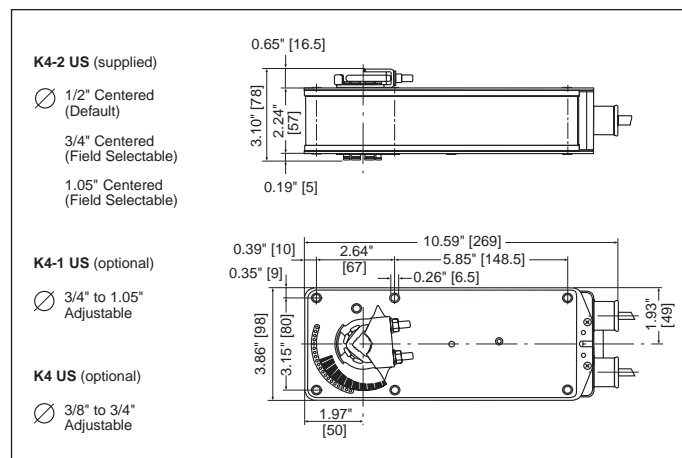

G20492-IG-Subject to change. © Belimo Aircontrols (USA), Inc.

Accessories

AV 10-18	Shaft extension
IND-AF2	Damper position indicator
K4 US	Universal clamp for 3/8" to 3/4" shafts
K4-1 US	Universal clamp for up to 1.05" dia jackshafts
K4-H	Universal clamp for hexshafts 3/8" to 5/8"
KH-AF	Crankarm for up to 3/4" round shaft (Series 2)
KH-AF-1	Crankarm for up to 1.05" jackshaft (Series 2)
KH-AFV	V-bolt kit for KH-AF and KH-AF-1
Tool-06	8mm and 10 mm wrench
ZG-HTR	Thermostat/Heater Kit
ZDB-AF2	Angle of rotation limiter
ZG-100	Universal mounting bracket
ZG-101	Universal mounting bracket
ZG-102	Multiple actuator mounting bracket
ZG-103	Universal mounting bracket
ZG-104	Universal mounting bracket
ZG-106	Mounting bracket for Honeywell® Mod IV replacement or new crankarm type installations
ZG-107	Mounting bracket for Honeywell® Mod III or Johnson® Series 100 replacement or new crankarm type installations
ZG-108	Mounting bracket for Barber Colman® MA 3../4.., Honeywell® Mod III or IV or Johnson® Series 100 replacement or new crankarm type installations
ZG-AF US	Crankarm adaptor kit for AF/NF
ZG-AF108	Crankarm adaptor kit for AF/NF
ZS-100	Weather shield (metal)
ZS-150	Weather shield (polycarbonate)
ZS-260	Explosion-proof housing
ZS-300	NEMA 4X housing

Note: When using AF24 US and AF24-S US actuators, only use accessories listed on this page.

Wiring diagrams

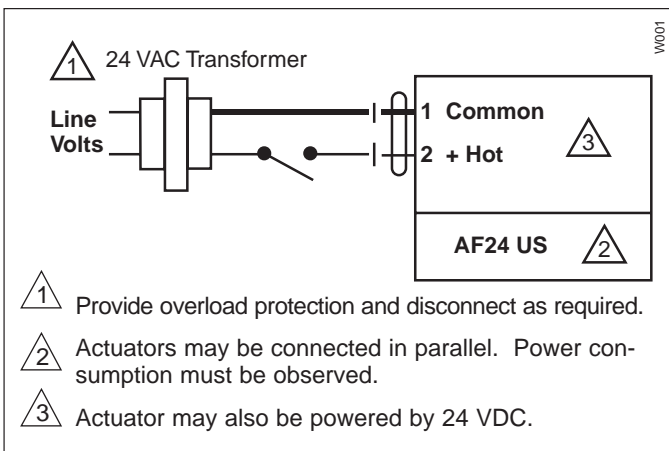

On-off wiring for AF24 US

AF24 (-S) US Typical Specification

On-off spring return damper actuators shall be direct coupled type which require no crankarm and linkage and be capable of direct mounting to a jackshaft up to a 1.05" diameter. The actuators must be designed so that they may be used for either clockwise or counterclockwise fail-safe operation. Actuators shall have a manual positioning mechanism accessible on its cover. Actuators shall use a brushless DC motor and be protected from overload at all angles of rotation. Run time shall be constant and independent of torque. If required, 2 SPDT auxiliary switches shall be provided with one switch having the capability of being adjustable. Actuators with switches must be constructed to meet the requirement for Double Insulation so an electrical ground connection is not required to meet agency listings. Actuators shall be UL listed and CSA certified, have a 5 year warranty, and be manufactured under ISO 9001 International Quality Control Standards. Actuators shall be as manufactured by Belimo.

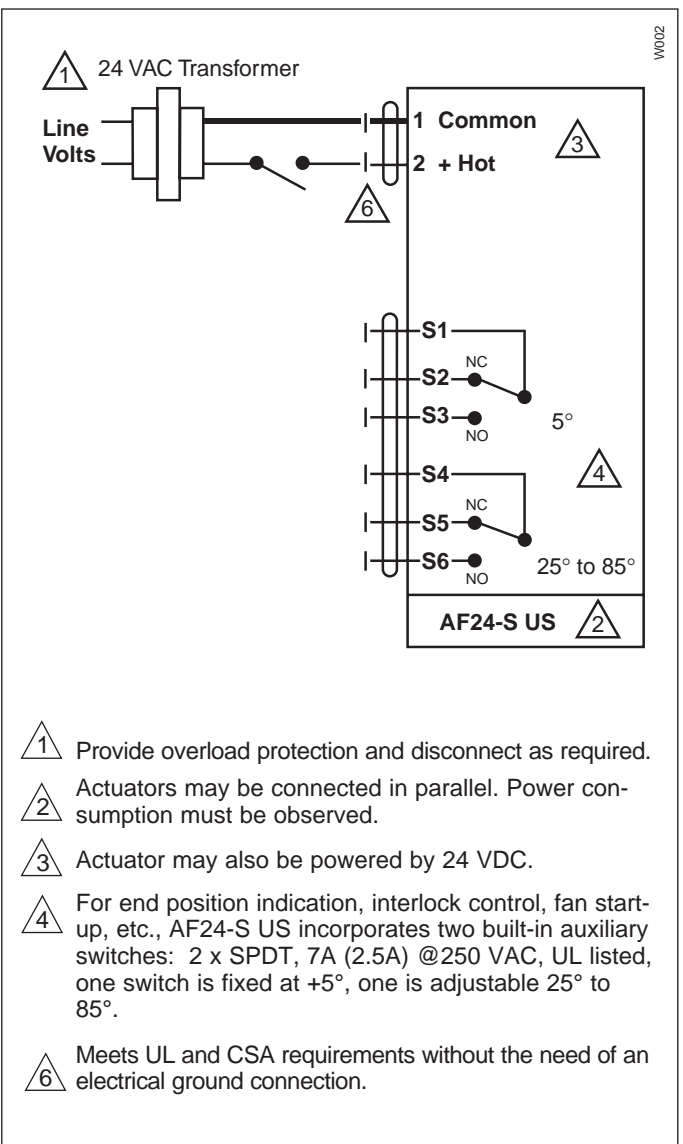

On-off wiring for AF24-S US

AF120 (-S) US, AF230 (-S) US

On-off, spring return failsafe, 120 or 230 VAC



Technical Data	AF120 (-S) US	AF230 (-S) US
Power supply	120 VAC \pm 10% 50/60 Hz	230 VAC \pm 14% 50/60 Hz
Power consumption	running: 6 W holding: 2.3 W	6.5 W 2.5 W
Transformer sizing	10 VA	11 VA
Electrical connection	3 ft, 18 GA appliance cable 1/2" conduit connector	
Electrical protection	actuators are double insulated	
Overload protection	electronic throughout 0° to 95° rotation	
Angle of rotation	95°, adjustable 35 to 95° w/ ZDB-AF2	
Torque	133 in-lb [15 Nm] constant	
Direction of rotation	reversible with CW/CCW mounting	
Position indication	visual indicator, 0° to 95° (0° is spring return position)	
Manual override	3mm hex crank (shipped w/actuator)	
Auxiliary switches (AF120/230-S)	2 x SPDT 7A (2.5A) @ 250 VAC, UL listed one set at +5°, one adjustable 25° to 85°	
Running time	150 sec. constant, independent of load, spring return < 20 sec	
Humidity	5 to 95% RH non-condensing	
Ambient temperature	-22°F to +122°F [-30°C to +50°C]	
Storage temperature	-40°F to +176°F [-40°C to +80°C]	
Housing	NEMA type 2 / IP54	
Housing material	zinc coated steel	
Agency listings	UL 873 listed, CSA C22.2 No. 24 certified	
Noise level	max. 45 dB (A)	
Servicing	maintenance free	
Quality standard	ISO 9001	
Weight	6.9 lbs (3.1 kg.)	

Torque min. 133 in-lb, for control of air dampers

Application

For on-off, fail-safe control of dampers in HVAC systems. Actuator sizing should be done in accordance with the damper manufacturer's specifications. Control is on-off from an auxiliary contact, or a manual switch.

The actuator is mounted directly to a damper shaft up to 1.05" in diameter by means of its universal clamp. A crankarm and several mounting brackets are available for applications where the actuator cannot be direct coupled to the damper shaft.

Operation

The AF series actuators provide true spring return operation for reliable fail-safe application and positive close off on air tight dampers. The spring return system provides consistent torque to the damper with, and without, power applied to the actuator.

The AF series provide 95° of rotation and are provided with a graduated position indicator showing 0° to 95°. The AF has a unique manual positioning mechanism which allows the setting of any damper position within its 95° of rotation. The AF series actuators are shipped at +5° (5° from full fail-safe) to provide automatic compression against damper gaskets for tight shut-off. When power is applied to the AF series, the manual mechanism is released. The actuators will now try to close against the 0° position during its normal control operations. The manual override can also be released physically by the use of a crank supplied with the actuator.

The AF uses a brushless DC motor which is controlled by an Application Specific Integrated Circuit (ASIC). The ASIC monitors and controls the actuator's rotation and provides a digital rotation sensing function to prevent damage to the actuator in a stall condition. The actuator may be stalled anywhere in its normal rotation without the need of mechanical end switches. The actuators are Double Insulated so a ground connection is not required.

The AF120/230-S US version is provided with 2 built-in auxiliary switches. These SPDT switches are provided for safety interfacing or signaling, for example, for fan start-up. The switching function at the fail-safe position is fixed at +5°, the other switch function is adjustable between +25° to +85°.

Dimensions [All numbers in brackets are in millimeters.]

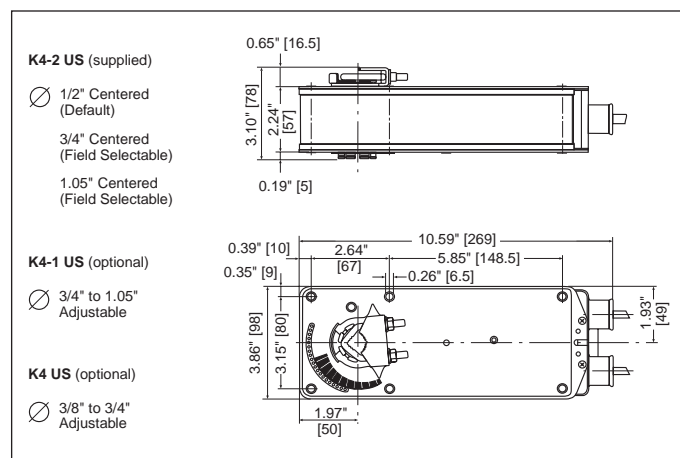

G20492-IG-Subject to change. © Belimo Aircontrols (USA), Inc.

Accessories

AV 10-18	Shaft extension
IND-AF2	Damper position indicator
K4 US	Universal clamp for 3/8" to 3/4" shafts
K4-1 US	Universal clamp for up to 1.05" dia jackshafts
KH-AF	Crankarm for up to 3/4" round shaft (Series 2)
KH-AF-1	Crankarm for up to 1.05" jackshaft (Series 2)
KH-AFV	V-bolt kit for KH-AF and KH-AF-1
Tool-06	8mm and 10 mm wrench
ZG-HTR	Thermostat/Heater Kit
ZDB-AF2	Angle of rotation limiter
ZG-100	Universal mounting bracket
ZG-101	Universal mounting bracket
ZG-102	Multiple actuator mounting bracket
ZG-103	Universal mounting bracket
ZG-104	Universal mounting bracket
ZG-106	Mounting bracket for Honeywell® Mod IV replacement or new crankarm type installations
ZG-107	Mounting bracket for Honeywell® Mod III or Johnson® Series 100 replacement or new crankarm type installations
ZG-108	Mounting bracket for Barber Colman® MA 3../4..., Honeywell® Mod III or IV or Johnson® Series 100 replacement or new crankarm type installations
ZG-AF US	Crankarm adaptor kit for AF/NF
ZG-AF108	Crankarm adaptor kit for AF/NF
ZS-100	Weather shield (metal)
ZS-150	Weather shield (polycarbonate)
ZS-260	Explosion-proof housing
ZS-300	NEMA 4X housing

Note: When using AF120/230 US and AF120/230-S US actuators, only use accessories listed on this page.

Wiring diagrams

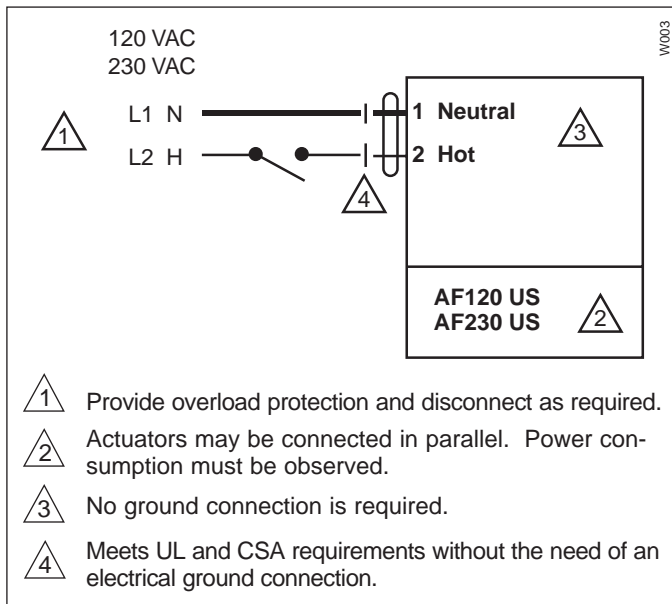

On-off wiring for AF120 US and AF230 US

AF120 US, AF230 US Typical Specification

On-off spring return damper actuators shall be direct coupled type which require no crankarm and linkage and be capable of direct mounting to a jackshaft up to a 1.05" diameter. The actuators must be designed so that they may be used for either clockwise or counterclockwise fail-safe operation. Actuators shall have a manual positioning mechanism accessible on its cover. Actuators shall use a brushless DC motor and be protected from overload at all angles of rotation. Run time shall be constant and independent of torque. If required, 2 SPDT auxiliary switches shall be provided with one switch having the capability of being adjustable. Actuators must be constructed to meet the requirement for Double Insulation so an electrical ground connection is not required to meet agency listings. Actuators shall be UL listed and CSA certified, have a 5 year warranty, and be manufactured under ISO 9001 International Quality Control Standards. Actuators shall be as manufactured by Belimo.

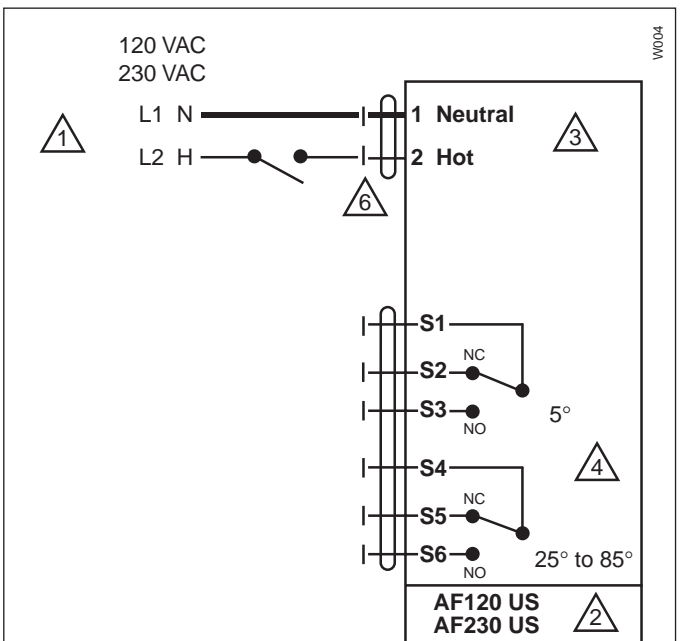

On-off wiring for AF120-S US and AF230-S US

AF24-SR US



Proportional damper actuator, spring return failsafe, 24 V for 2 to 10 VDC and 4 to 20 mA control signal. Output signal of 2 to 10 VDC for position indication



Torque min. 133 in-lb, for control of air dampers

Application

For proportional modulation of dampers in HVAC systems. Actuator sizing should be done in accordance with the damper manufacturer's specifications.

The actuator is mounted directly to a damper shaft up to 1.05" in diameter by means of its universal clamp. A crankarm and several mounting brackets are available for applications where the actuator cannot be direct coupled to the damper shaft.

The actuator operates in response to a 2 to 10 VDC, with the addition of a 500Ω resistor, a 4 to 20 mA control input from an electronic controller or positioner. A 2 to 10 VDC feedback signal is provided for position indication or master-slave applications.

Operation

The AF series actuators provide true spring return operation for reliable fail-safe application and positive close-off on air tight dampers. The spring return system provides constant torque to the damper with, and without, power applied to the actuator.

The AF series provides 95° of rotation and is provided with a graduated position indicator showing 0 to 95°. The AF has a unique manual positioning mechanism which allows the setting of any damper position within its 95° of rotation. The actuator is shipped at +5° position (5° from full fail-safe) to provide automatic compression against damper gaskets for tight shut-off. When power is applied, the manual mechanism is released and the actuator drives toward the full fail-safe position. The actuator will memorize the angle where it stops rotating and use this point for its zero position for its normal control operations. The manual override can also be released physically by the use of a crank supplied with the actuator.

The AF uses a brushless DC motor which is controlled by an Application Specific Integrated Circuit (ASIC) and a microprocessor. The microprocessor provides the intelligence to the ASIC to provide a constant rotation rate and to know the actuator's exact zero position. The ASIC monitors and controls the brushless DC motor's rotation and provides a digital rotation sensing function to prevent damage to the actuator in a stall condition. The actuator may be stalled anywhere in its normal rotation without the need of mechanical end switches.

Technical Data	AF24-SR US
Power supply	24 VAC ± 20% 50/60 Hz 24 VDC ± 10%
Power consumption	running: 6 W ; holding: 2 W
Transformer sizing	10 VA (class 2 power source)
Electrical connection	3 ft, 18 GA appliance cable 1/2" conduit connector
Overload protection	electronic throughout 0 to 95° rotation
Operating range Y	2 to 10 VDC, 4 to 20 mA
Input impedance	100 kΩ (0.1 mA), 500Ω
Feedback output U	2 to 10 VDC (max. 0.5 mA) for 95°
Angle of rotation	mechanically limited to 95°
Torque	133 in-lb [15 Nm] constant
Direction of rotation	spring: reversible with cw/ccw mounting motor: reversible with built-in switch
Position indication	visual indicator, 0° to 95° (0° is spring return position)
Manual override	3mm hex crank (shipped w/actuator)
Running time	150 sec. constant, independent of load, spring return < 20 sec
Humidity	5 to 95% RH non-condensing
Ambient temperature	-22°F to +122°F [-30°C to +50°C]
Storage temperature	-40°F to +176°F [-40°C to +80°C]
Housing	NEMA type 2 / IP54
Housing material	zinc coated metal
Agency listings	UL 873 listed, CSA C22.2 No. 24 certified
Noise level	max. 45 dB (A)
Servicing	maintenance free
Quality standard	ISO 9001
Weight	6.0 lbs (2.7 kg.)

Dimensions [All numbers in brackets are in millimeters.]

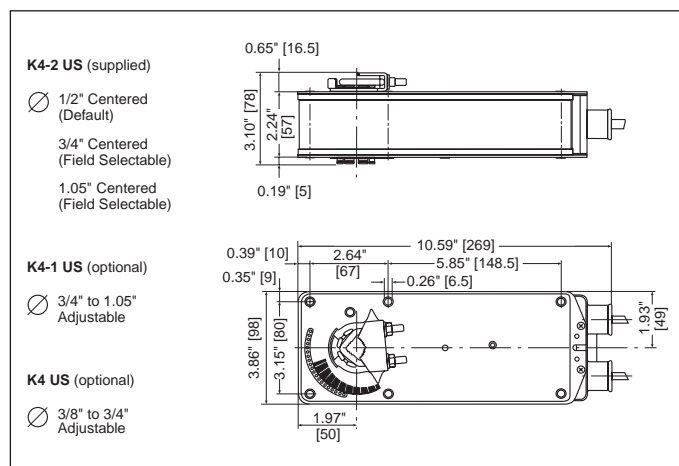

Proportional damper actuator, spring return failsafe, 24 V for 2 to 10 VDC and 4 to 20 mA control signal. Output signal of 2 to 10 VDC for position indication

Accessories

AV 10-18	Shaft extension
IND-AF2	Damper position indicator
K4 US	Universal clamp for 3/8" to 3/4" shafts
K4-1 US	Universal clamp for up to 1.05" dia jackshafts
K4-H	Universal clamp for hexshafts 3/8" to 5/8"
KH-AF	Crankarm for up to 3/4" round shaft (Series 2)
KH-AF-1	Crankarm for up to 1.05" jackshaft (Series 2)
KH-AFV	V-bolt kit for KH-AF and KH-AF-1
Tool-06	8mm and 10 mm wrench
SGA24	Min. and/or man. positioner in NEMA 4 housing
SGF24	Min. and/or man. positioner for flush panel mounting
ZG-R01	500Ω resistor for 4 to 20 mA control signal
ZG-HTR	Thermostat/Heater Kit
ZDB-AF2	Angle of rotation limiter
ZG-100	Universal mounting bracket
ZG-101	Universal mounting bracket
ZG-102	Multiple actuator mounting bracket
ZG-103	Universal mounting bracket
ZG-104	Universal mounting bracket
ZG-106	Mounting bracket for Honeywell® Mod IV replacement or new crankarm type installations
ZG-107	Mounting bracket for Honeywell® Mod III or Johnson® Series 100 replacement or new crankarm type installations
ZG-108	Mounting bracket for Barber Colman® MA 3../4., Honeywell® Mod III or IV or Johnson® Series 100 replacement or new crankarm type installations
ZG-AF US	Crankarm adaptor kit for AF/NF
ZG-AF108	Crankarm adaptor kit for AF/NF
ZS-100	Weather shield (metal)
ZS-150	Weather shield (polycarbonate)
ZS-260	Explosion-proof housing
ZS-300	NEMA 4X housing

Note: When using AF24-SR US actuators, only use accessories listed on this page.

AF24-SR US Typical Specification

Spring return control damper actuators shall be direct coupled type which require no crankarm and linkage and be capable of direct mounting to a jackshaft up to a 1.05" diameter. The actuator must provide proportional damper control in response to a 2 to 10 VDC or, with the addition of a 500Ω resistor, a 4 to 20 mA control input from an electronic controller or positioner. The actuators must be designed so that they may be used for either clockwise or counter-clockwise fail-safe operation. Actuators shall have control direction of rotation switch accessible on its cover. Actuators shall use a brushless DC motor controlled by a microprocessor and be protected from overload at all angles of rotation. Run time shall be constant, and independent of torque. A 2 to 10 VDC feedback signal shall be provided for position feedback or master-slave applications. Actuators shall be UL listed and CSA certified, have a 5 year warranty, and be manufactured under ISO 9001 International Quality Control Standards. Actuators shall be as manufactured by Belimo.

AF

Wiring diagrams

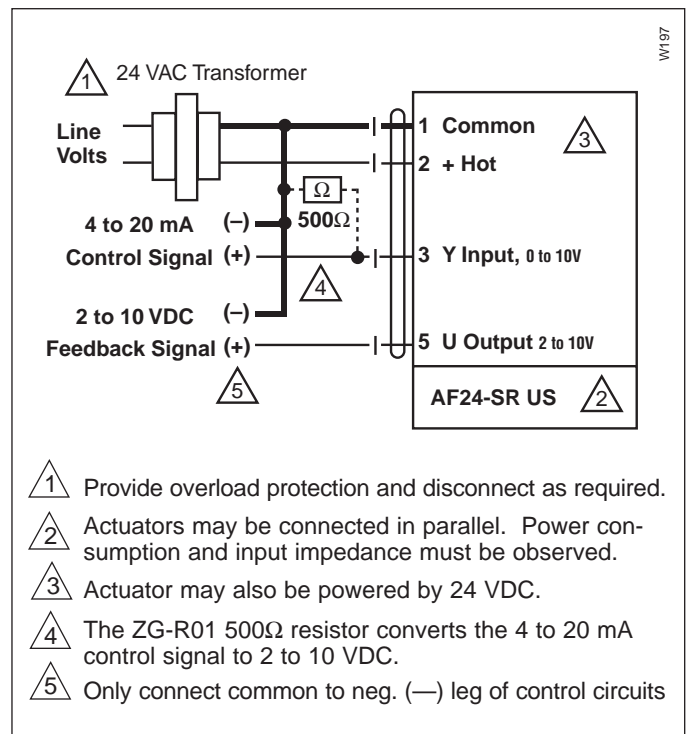
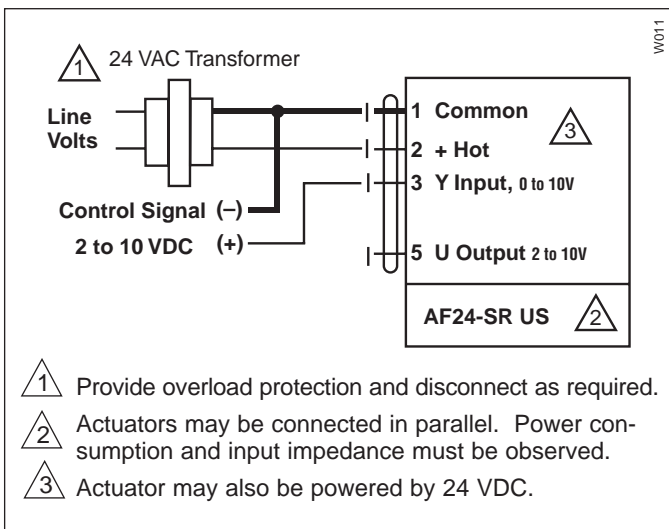

AF24-PC US



Proportional damper actuator, spring return failsafe, 24 V for 0 to 20 V phasecut control signal.
Output signal of 2 to 10 VDC for position indication



Torque min. 133 in-lb, for control of air dampers

Application

For proportional modulation of dampers in HVAC systems. Actuator sizing should be done in accordance with the damper manufacturer's specifications.

The actuator is mounted directly to a damper shaft up to 1.05" in diameter by means of its universal clamp. A crankarm and several mounting brackets are available for applications where the actuator cannot be direct coupled to the damper shaft.

The actuator operates in response to a 0-10 V phasecut control input from an electronic controller or positioner. A 2 to 10 VDC feedback signal is provided for position indication or master-slave applications.

Operation

The AF series actuators provide true spring return operation for reliable fail-safe application and positive close-off on air tight dampers. The spring return system provides constant torque to the damper with, and without, power applied to the actuator.

The AF series provides 95° of rotation and is provided with a graduated position indicator showing 0° to 95°. The AF has a unique manual positioning mechanism which allows the setting of any damper position within its 95° of rotation. When power is applied to the AFR series its "one time use" mechanism is released. The actuator is shipped at +5° (5° from full fail-safe) to provide automatic compression against damper gaskets for tight shut-off. When power is applied, the manual mechanism is released and the actuator drives toward the full fail-safe position. The actuator will memorize the angle where it stops rotating and use this point for its zero position for its normal control operations. The manual override can also be released physically by the use of a crank supplied with the actuator.

The AF uses a brushless DC motor which is controlled by an Application Specific Integrated Circuit (ASIC) and a microprocessor. The microprocessor provides the intelligence to the ASIC to provide a constant rotation rate and to know the actuator's exact zero position. The ASIC monitors and controls the brushless DC motor's rotation and provides a digital rotation sensing function to prevent damage to the actuator in a stall condition. The actuator may be stalled anywhere in its normal rotation without the need of mechanical end switches.

Technical Data	AF24-PC US
Power supply	24 VAC ± 20% 50/60 Hz 24 VDC ± 10%
Power consumption	running: 6 W ; holding: 2.5 W
Transformer sizing	10 VA (class 2 power source)
Electrical connection	3 ft, 18 GA appliance cable 1/2" conduit connector
Overload protection	electronic throughout 0 to 95° rotation
Operating range Y	0 to 10 V phasecut
Input impedance	8 kΩ (0.1 mA), 50mW
Feedback output U	2 to 10 VDC (max. 0.5 mA) for 95°
Angle of rotation	mechanically limited to 95°
Torque	133 in-lb [15 Nm] constant
Direction of rotation	spring: reversible with cw/ccw mounting motor: reversible with built-in switch
Position indication	visual indicator, 0° to 95° (0° is spring return position)
Manual override	3mm hex crank (shipped w/actuator)
Running time	150 sec. constant, independent of load, spring return < 20 sec
Humidity	5 to 95% RH non-condensing
Ambient temperature	-22°F to +122°F [-30°C to +50°C]
Storage temperature	-40°F to +176°F [-40°C to +80°C]
Housing	NEMA type 2 / IP54
Housing material	zinc coated metal
Agency listings	UL 873 listed, CSA C22.2 No. 24 certified
Noise level	max. 45 dB (A)
Servicing	maintenance free
Quality standard	ISO 9001
Weight	6.0 lbs (2.7 kg.)

Dimensions [All numbers in brackets are in millimeters.]

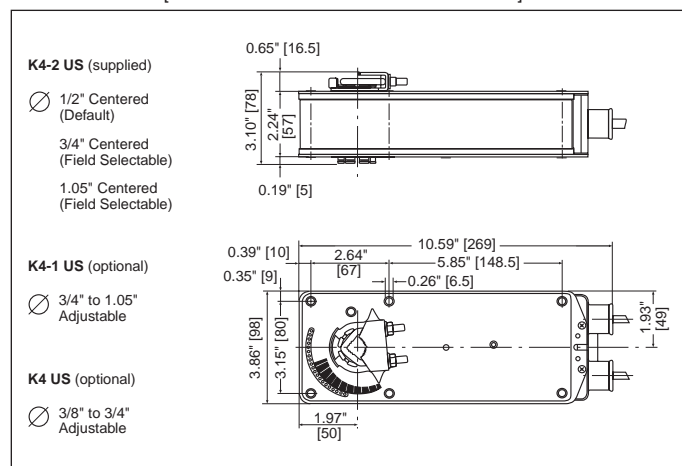

G20492-IG-Subject to change. © Belimo Aircontrols (USA), Inc.

D001

Proportional damper actuator, spring return failsafe, 24 V for 0 to 20 V phasecut control signal.
Output signal of 2 to 10 VDC for position indication

Accessories

AV 10-18	Shaft extension
IND-AF2	Damper position indicator
K4 US	Universal clamp for 3/8" to 3/4" shafts
K4-1 US	Universal clamp for up to 1.05" dia jackshafts
K4-H	Universal clamp for hexshafts 3/8" to 5/8"
KH-AF	Crankarm for up to 3/4" round shaft (Series 2)
KH-AF-1	Crankarm for up to 1.05" jackshaft (Series 2)
KH-AFV	V-bolt kit for KH-AF and KH-AF-1
Tool-06	8mm and 10 mm wrench
SGA24	Min. and/or man. positioner in NEMA 4 housing
SGF24	Min. and/or man. positioner for flush panel mounting
ZG-R01	500Ω resistor for 4 to 20 mA control signal
ZG-HTR	Thermostat/Heater Kit
ZDB-AF2	Angle of rotation limiter
ZG-100	Universal mounting bracket
ZG-101	Universal mounting bracket
ZG-102	Multiple actuator mounting bracket
ZG-103	Universal mounting bracket
ZG-104	Universal mounting bracket
ZG-106	Mounting bracket for Honeywell® Mod IV replacement or new crankarm type installations
ZG-107	Mounting bracket for Honeywell® Mod III or Johnson® Series 100 replacement or new crankarm type installations
ZG-108	Mounting bracket for Barber Colman® MA 3../4..., Honeywell® Mod III or IV or Johnson® Series 100 replacement or new crankarm type installations
ZG-AF US	Crankarm adaptor kit for AF/NF
ZG-AF108	Crankarm adaptor kit for AF/NF
ZS-100	Weather shield (metal)
ZS-150	Weather shield (polycarbonate)
ZS-260	Explosion-proof housing
ZS-300	NEMA 4X housing

AF24-PC US Typical Specification

Spring return control damper actuators shall be direct coupled type which require no crankarm and linkage and be capable of direct mounting to a jackshaft up to a 1.05" diameter. The actuator must provide proportional damper control in response to a 0 to 20 V phasecut control output from an electronic controller or positioner. The actuators must be designed so that they may be used for either clockwise or counterclockwise fail-safe operation. Actuators shall have control direction of rotation switch accessible on its cover. Actuators shall use a brushless DC motor controlled by a micro-processor and be protected from overload at all angles of rotation. Run time shall be constant, and independent of torque. A 2 to 10 VDC feedback signal shall be provided for position feedback or master-slave applications. Actuators shall be UL listed and CSA certified, have a 5 year warranty, and be manufactured under ISO 9001 International Quality Control Standards. Actuators shall be as manufactured by Belimo.

Note: When using AF24-PC US actuators, only use accessories listed on this page.

Wiring diagrams

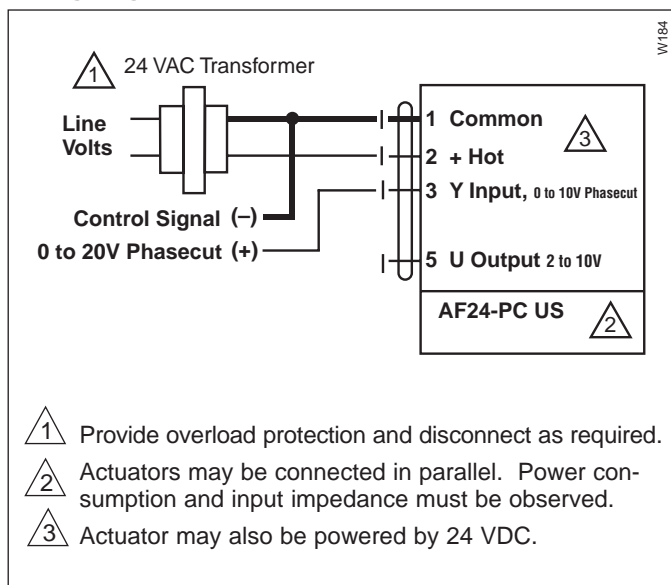

0 to 20 V phasecut control of AF24-PC US

AF24-MFT (-S) US

Proportional damper actuator, spring return failsafe, Multi-Function Technology®

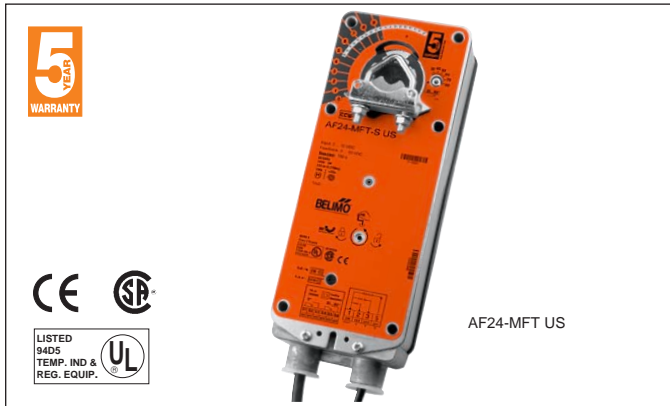

Technical Data	AF24-MFT (-S) US
Power supply	24 VAC, ± 20%, 50/60 Hz 24 VDC, ±10%
Power consumption	2.5 W holding 6 W running
Transformer sizing	10 VA (Class 2 power source)
Electrical connection	3 ft, 18 GA, appliance cable, 1/2" conduit connector
Overload protection	electronic throughout 0 to 95° rotation
Operating range Y*	2 to 10 VDC 4 to 20 mA (w/500 Ω, 1/4 W resistor) ZG-R01
Input impedance	100kΩ for 2 to 10 VDC (0.1 mA) 500Ω for 4 to 20 mA 1500Ω for PWM, Floating point and On-Off control
Feedback output U*	2 to 10 VDC, 0.5 mA max
Torque	min 133 in-lb (15 Nm)
Direction of rotation*	spring: reversible with cw/ccw mounting motor: reversible with built-in switch
Mech. angle of rotation*	95°, adjustable 35° to 95° w/ZDB-AF2
Running time motor*	150 seconds constant
Running time spring	<20 sec spring return fail safe position
Angle of Rotation Adaptation*	Off (Default)
Override control*	Min. (Min Position) = 0% - ZS (Mid. Position) = 50% - Max. (Max. Position) = 100%
Position indication	visual indicator, 0° to 95° (0° is spring return position)
Auxiliary switches (AF24-MFT-S US)	2 x SPDT 7A (2.5A) @ 250 VAC, UL listed one set at +5°, one adjustable 25° to 85°
Manual override	3 mm hex crank (supplied)
Humidity	5 to 95% RH, non-condensing
Ambient temperature	-22 to +122° F (-30 to +50° C)
Storage temperature	-40 to +176° F (-40 to +80° C)
Housing	NEMA 2, IP54
Housing material	zinc coated metal
Noise level	less than 45 dB (A)
Agency listings	UL 873 listed, CE, CSA C22.2 No. 24 certified
Quality standard	ISO 9001
Servicing	maintenance free
Weight	6.0 lbs. (2.7 kg.)

* Variable when configured with MFT options

- Torque min. 133 in-lb
- Control 2 to 10 VDC (DEFAULT)
- Feedback 2 to 10 VDC (DEFAULT)

Application

For proportional modulation of dampers and control valves in HVAC systems. The AF24-MFT US provides mechanical spring return operation for reliable fail-safe application.

Default/Configuration

Default parameters for 2 to 10 VDC applications of the AF24-MFT US actuator are assigned during manufacturing. If required, custom versions of the actuator can be ordered. The parameters noted in the Technical Data table are variable.

These parameters can be changed by three means:

- Pre-set configurations from Belimo
- Custom configurations from Belimo
- Configurations set by the customer using the MFT-Handy® or the MFT-Actuate™ PC software application.

Operation

The AF24-MFT US actuator provides 95° of rotation and is provided with a graduated position indicator showing 0° to 95°. The actuator will synchronize the 0° mechanical stop or the physical damper or valve mechanical stop and use this point for its zero position during normal control operations. A unique manual override allows the setting of any actuator position within its 95° of rotation with no power applied. This mechanism can be released physically by the use of a crank supplied with the actuator. When power is applied the manual override is released and the actuator drives toward the fail-safe position.

The actuator uses a brushless DC motor which is controlled by an Application Specific Integrated Circuit (ASIC) and a microprocessor. The microprocessor provides the intelligence to the ASIC to provide a constant rotation rate and to know the actuator's exact position. The ASIC monitors and controls the brushless DC motor's rotation and provides a Digital Rotation Sensing (DRS) function to prevent damage to the actuator in a stall condition. The position feedback signal is generated without the need for mechanical feedback potentiometers using DRS. The actuator may be stalled anywhere in its normal rotation without the need of mechanical end switches.

The AF24-MFT US is mounted directly to control shafts up to 1.05" diameter by means of its universal clamp and anti-rotation bracket. A crankarm and several mounting brackets are available for damper applications where the actuator cannot be directly coupled to the damper shaft. The spring return system provides minimum specified torque to the application during a power interruption. The AF24-MFT US actuator is shipped at +5° (5° from full fail-safe) to provide automatic compression against damper gaskets for tight shut-off.

Dimensions [All numbers in brackets are in millimeters.]

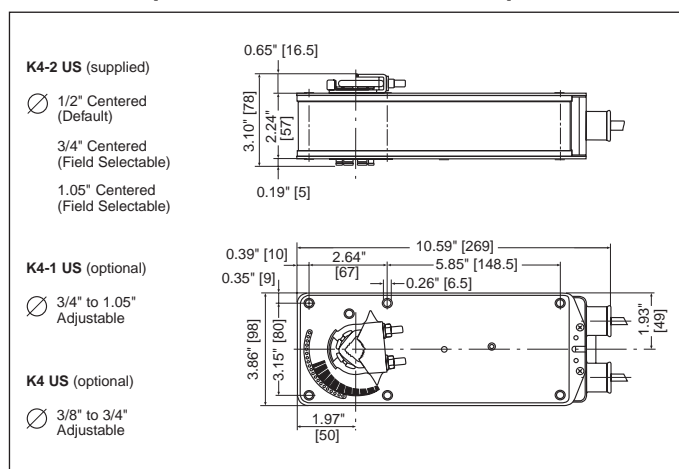

G20492-IG-Subject to change. © Belimo Aircontrols (USA), Inc.

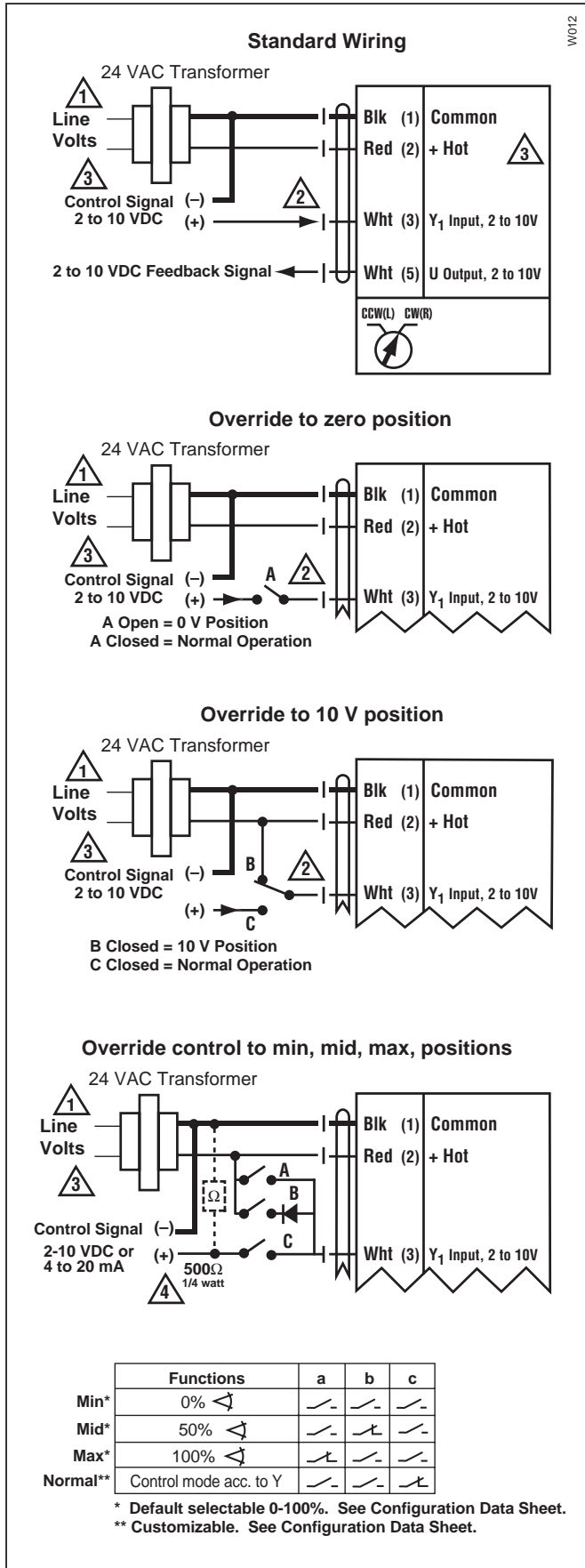

W012

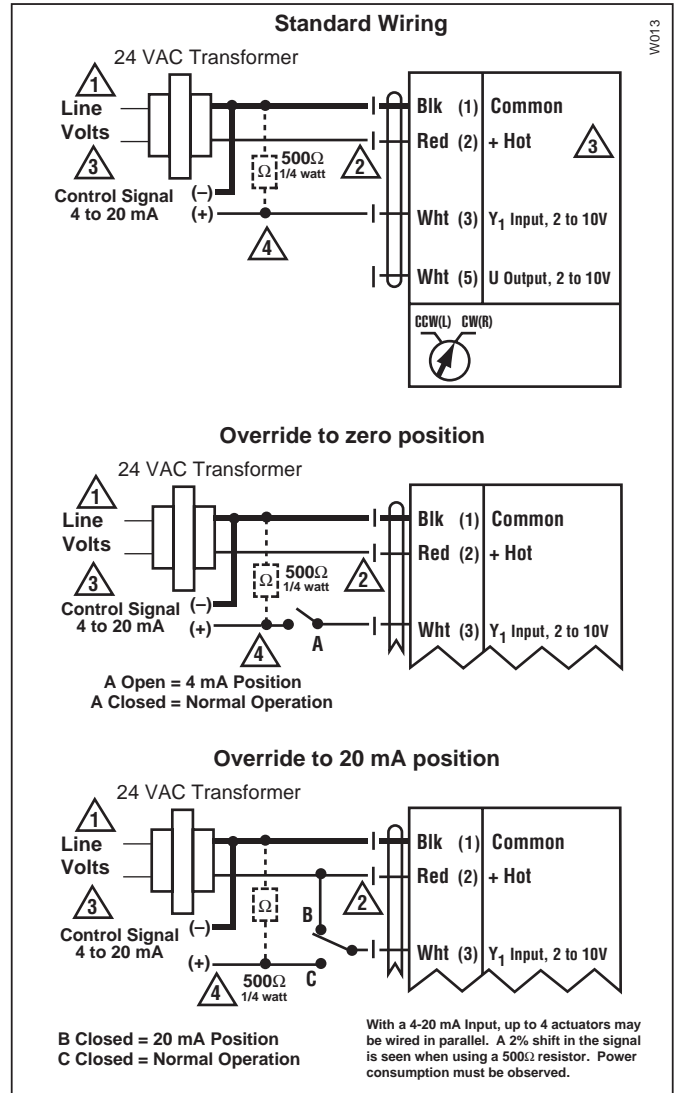

W013

4 to 20 mA Control Signal

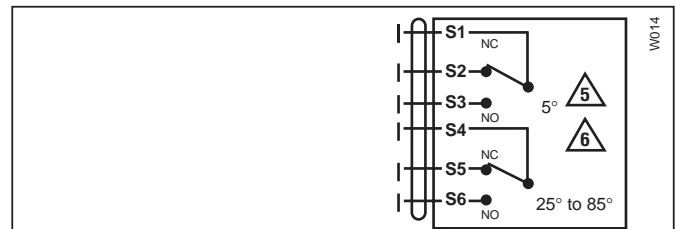

W014

Auxiliary Switch AF24-MFT-S US

Notes

- 1 Provide overload protection and disconnect as required.
- 2 Actuators may be connected in parallel if not mechanically mounted to the same shaft. Power consumption and input impedance must be observed.
- 3 Actuator may also be powered by 24 VDC.
- 4 ZG-R01 may be used.
- 5 For end position indication, interlock control, fan startup, etc., AF24-MFT-S US incorporates two built-in auxiliary switches: 2 x SPDT, 7A (2.5A) @250 VAC, UL listed, one switch is fixed at +5°, one is adjustable 25° to 85°.
- 6 Meets UL and CSA requirements without the need of an electrical ground connection.

AF24-MFT95 US



Proportional damper actuator, spring return failsafe, 24 V for use with Honeywell® electronic Series 90, or a 0 to 135Ω input



- Torque min. 133 in-lb
- Control fixed, 0 to 135Ω input, or Honeywell series 90 (fixed)
- Feedback 2 to 10 VDC (DEFAULT)

Application

For proportional modulation of dampers and control valves in HVAC systems. The AF24-MFT95 US provides mechanical spring return operation for reliable fail-safe application.

Default/Configuration

Default parameters for 0 to 135Ω Input applications of the AF24-MFT95 US actuator are assigned during manufacturing. If required, custom versions of the actuator can be ordered. However the control input cannot be modified via MFT-Handy tool or PC-software. The parameters noted in the Technical Data table are variable.

These parameters can be changed by three means:

- Pre-set configurations from Belimo
- Custom configurations from Belimo
- Configurations set by the customer using the MFT-Handy® or the MFT-Actuate™ PC software application.

Operation

The AF24-MFT95 US actuator provides 95° of rotation and is provided with a graduated position indicator showing 0° to 95°. The actuator will synchronize the 0° mechanical stop or the physical damper or valve mechanical stop and use this point for its zero position during normal control operations. A unique manual override allows the setting of any actuator position within its 95° of rotation with no power applied. This mechanism can be released physically by the use of a crank supplied with the actuator. When power is applied the manual override is released and the actuator drives toward the fail-safe position.

The actuator uses a brushless DC motor which is controlled by an Application Specific Integrated Circuit (ASIC) and a microprocessor. The microprocessor provides the intelligence to the ASIC to provide a constant rotation rate and to know the actuator's exact position. The ASIC monitors and controls the brushless DC motor's rotation and provides a Digital Rotation Sensing (DRS) function to prevent damage to the actuator in a stall condition. The position feedback signal is generated without the need for mechanical feedback potentiometers using DRS. The actuator may be stalled anywhere in its normal rotation without the need of mechanical end switches.

The AF24-MFT95 US is mounted directly to control shafts up to 1.05" diameter by means of its universal clamp and anti-rotation bracket. A crankarm and several mounting brackets are available for damper applications where the actuator cannot be direct coupled to the damper shaft. The spring return system provides minimum specified torque to the application during a power interruption. The AF24-MFT95 US actuator is shipped at +5° (5° from full fail-safe) to provide automatic compression against damper gaskets for tight shut-off.

Dimensions [All numbers in brackets are in millimeters.]

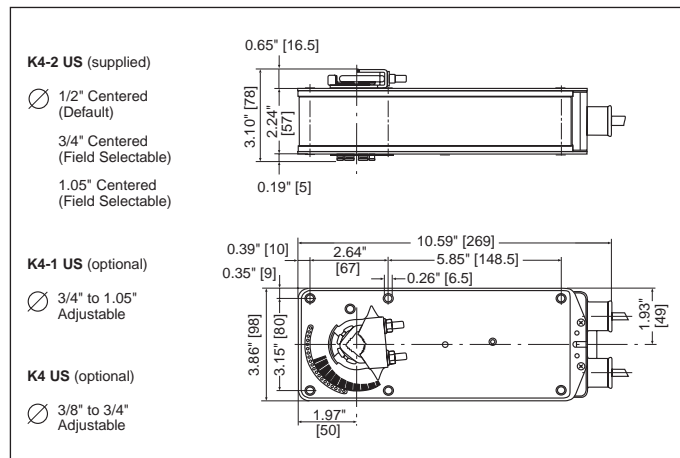

Technical Data	AF24-MFT95 US
Power supply	24 VAC ± 20% 50/60 Hz 24 VDC ± 10%
Power consumption	running: 6 W ; holding: 2 W
Transformer sizing	10 VA (class 2 power source)
Electrical connection	3 ft, 18 GA appliance cable 1/2" conduit connector
Overload protection	electronic throughout 0 to 95° rotation
Operating range WRB (Not selectable via MFT)	0 to 135Ω Honeywell electronic series 90, or a 0 to 135 Ω input
Feedback output U*	2 to 10 VDC, 0.5 mA max
Mech. angle of rotation*	95°, adjustable 35° to 95° w/ZDB-AF2
Torque	133 in-lb [15 Nm] constant
Direction of rotation*	spring: reversible with cw/ccw mounting motor: reversible with built-in switch
Position indication	visual indicator, 0° to 95° (0° is spring return position)
Manual override	3mm hex crank (shipped w/actuator)
Running time motor*	150 seconds constant
Running time spring	<20 sec spring return fail safe position
Angle of Rotation Adaptation*	Off (Default)
Override control*	Min. (Min Position) = 0% - ZS (Mid. Position) = 50% - Max. (Max. Position) = 100%
Humidity	5 to 95% RH non-condensing
Ambient temperature	-22°F to +122°F [-30°C to +50°C]
Storage temperature	-40°F to +176°F [-40°C to +80°C]
Housing	NEMA type 2 / IP54
Housing material	zinc coated metal
Agency listings	UL 873 listed, CE, CSA C22.2 No. 24 certified
Noise level	max. 45 dB (A)
Servicing	maintenance free
Quality standard	ISO 9001
Weight	6.0 lbs (2.7 kg.)

* Variable when configured with MFT options

Proportional damper actuator, spring return failsafe, 24 V for use with Honeywell® electronic Series 90, or a 0 to 135Ω input

Proportional Potentiometric Control

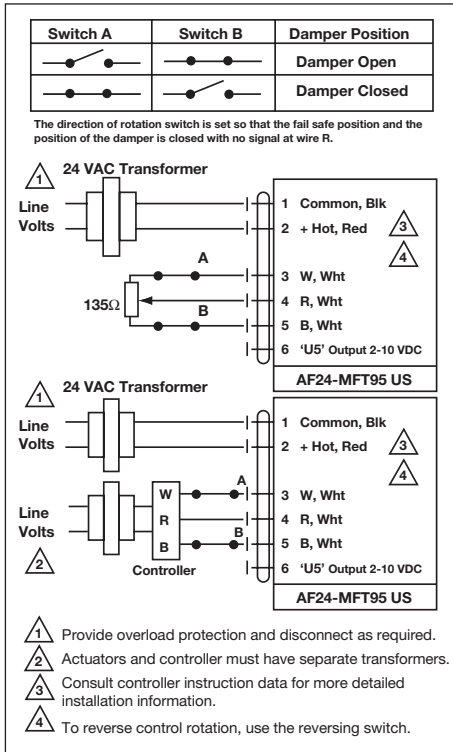

Override of AF24-MFT95 US

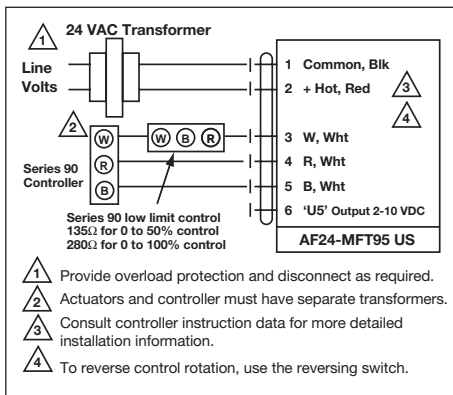

AF24-MFT95 US used with a Series 90 controller and a Series 90 low limit control

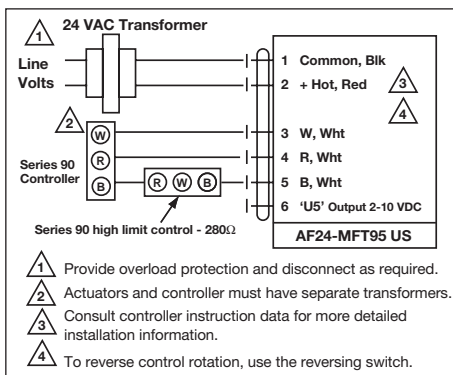

AF24-MFT95 US used with a Series 90 controller and a Series 90 high limit control

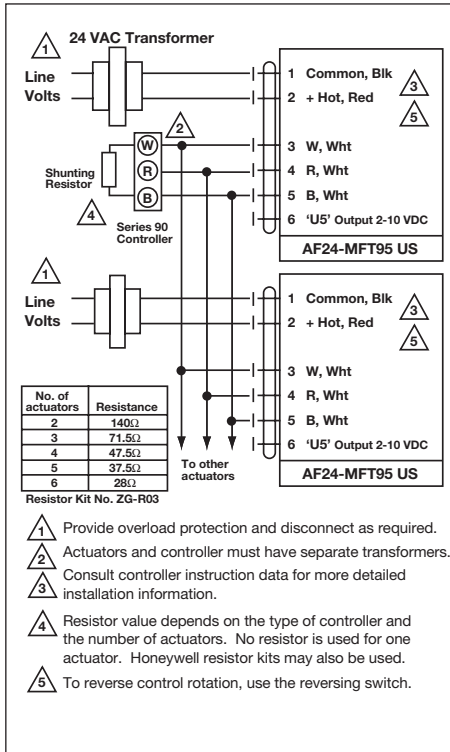

Wiring multiple actuators to a Series 90 controller.

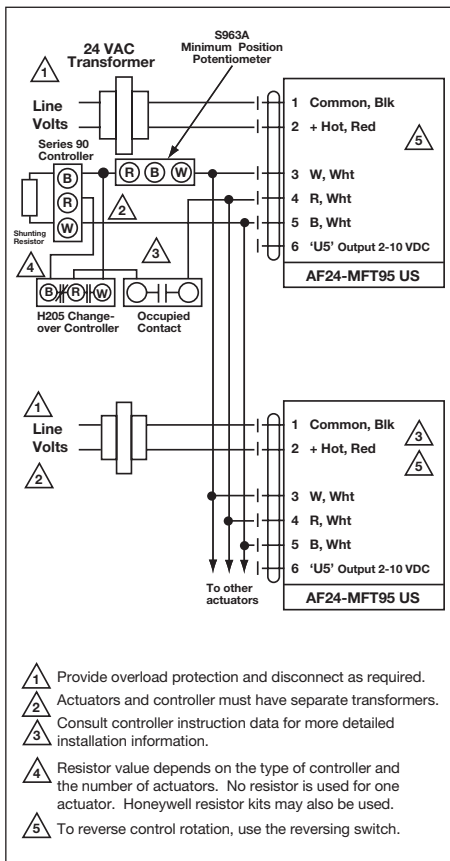

Wiring multiple actuators to a Series 90 controller using a minimum position potentiometer.

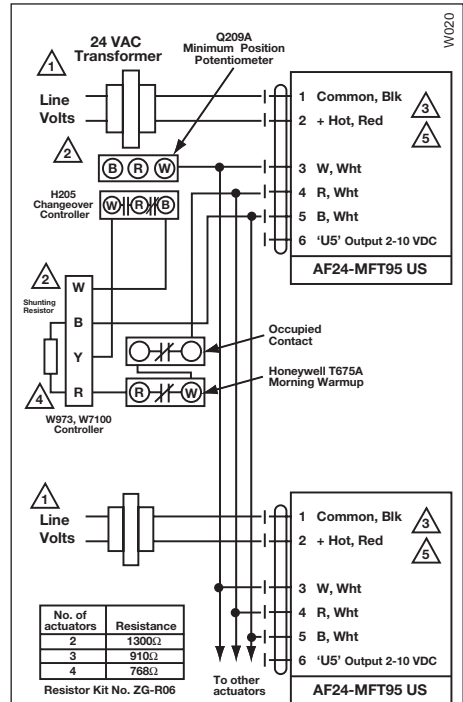

Used with the W973 and W7100 controllers.

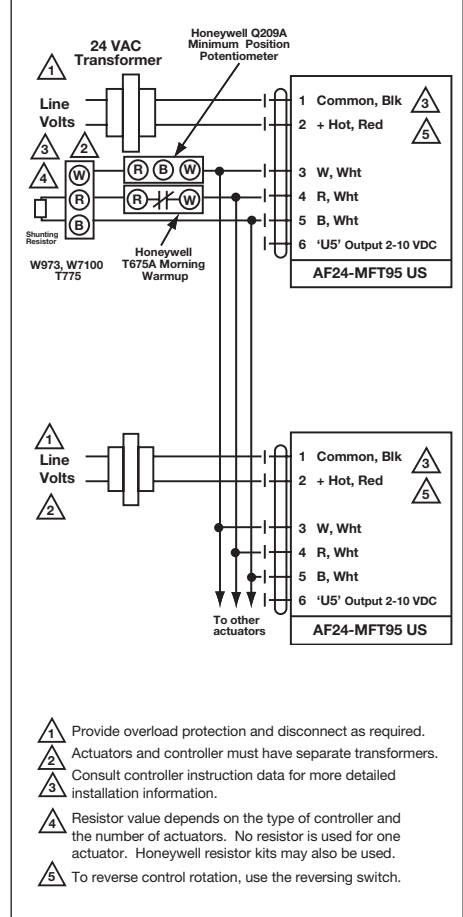

Typical wiring diagrams for multiple actuators used with the W973, W7100 and T775 controllers.

Installation Instructions

Quick-Mount Visual Instructions for Mechanical Installation

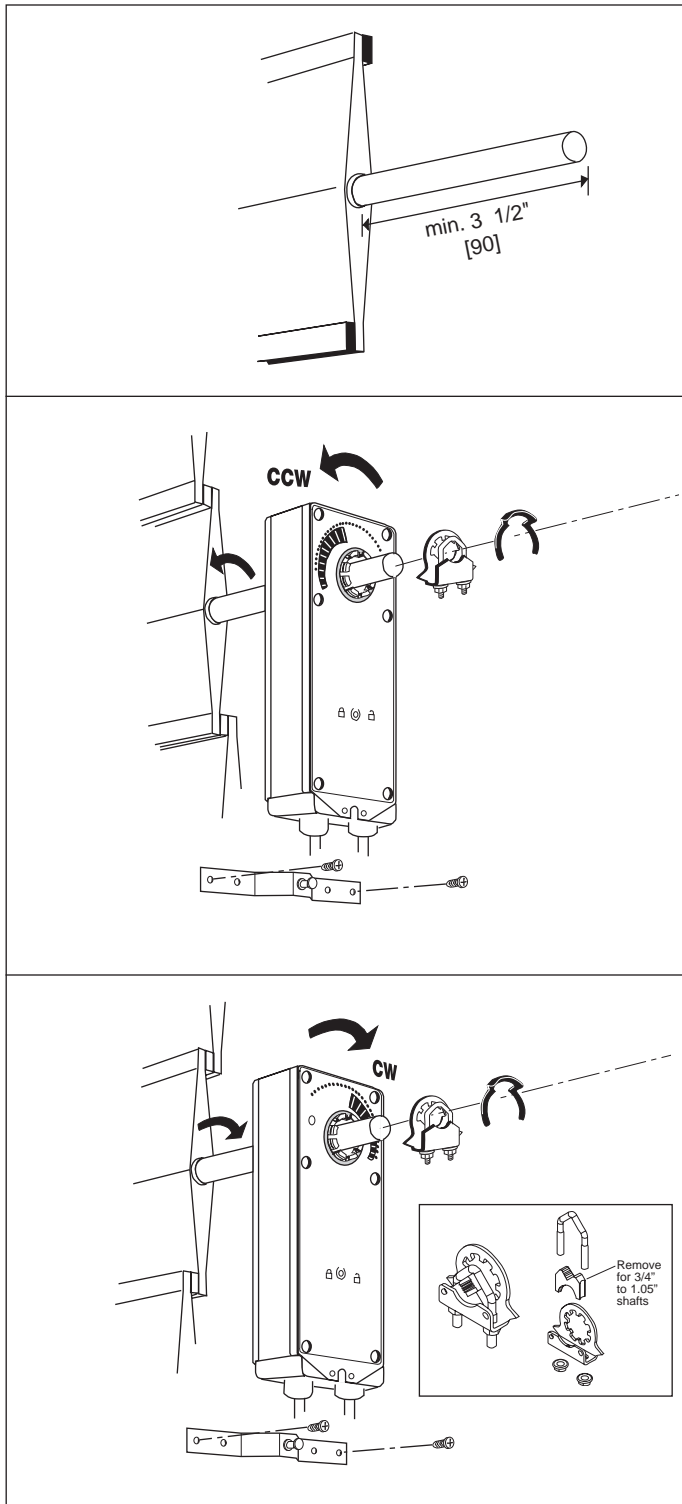

Dimensions (All numbers in brackets are in millimeters.)

QUICK-MOUNT VISUAL INSTRUCTIONS

1. Rotate the damper to its fail-safe position. If the shaft rotates counterclockwise, mount the "CCW" side of the actuator out. If it rotates clockwise, mount the actuator with the "CW" side out.
2. If the universal clamp is not on the correct side of the actuator, move it to the correct side.

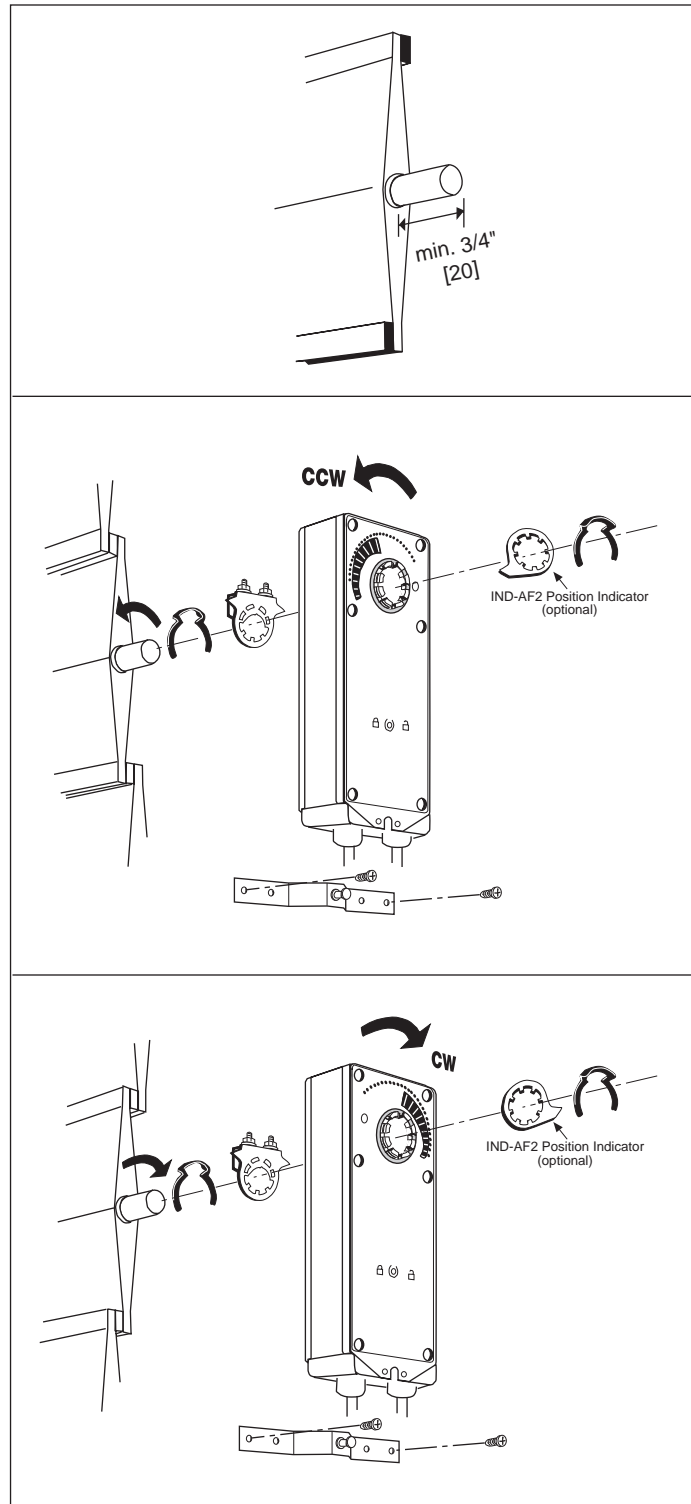

3. Slide the actuator onto the shaft and tighten the nuts on the V-bolt with a 10mm wrench to 6-8 ft-lb of torque.
4. Slide the anti-rotation strap under the actuator so that it engages the slot at the base of the actuator. Secure the strap to the duct work with #8 self-tapping screws.

NOTE: Read the "Standard Mounting" instructions, on the next page, for more detailed information.

Determining Torque Loading and Actuator Sizing

Damper torque loadings, used in selecting the correct size actuator, should be provided by the damper manufacturer. If this information is not available, the following general selection guidelines can be used.

Damper Type	Torque Loading
Opposed blade, without edge seals, for non-tight close-off applications	3 in-lb/sq. ft.
Parallel blade, without edge seals, for non-tight close-off applications	4 in-lb/sq. ft.
Opposed blade, with edge seals, for tight close-off applications	5 in-lb/sq. ft.
Parallel blade, with edge seals, for tight close-off applications	7 in-lb/sq. ft.

The above torque loadings will work for most applications under 2 in. w.g. static pressure or 1000 FPM face velocity. For applications between this criteria and 3 in. w.g. or 2500 FPM, the torque loading should be increased by a multiplier of 1.5. If the application calls for higher criteria up to 4 in. w.g. or 3000 FPM, use a multiplier of 2.0.

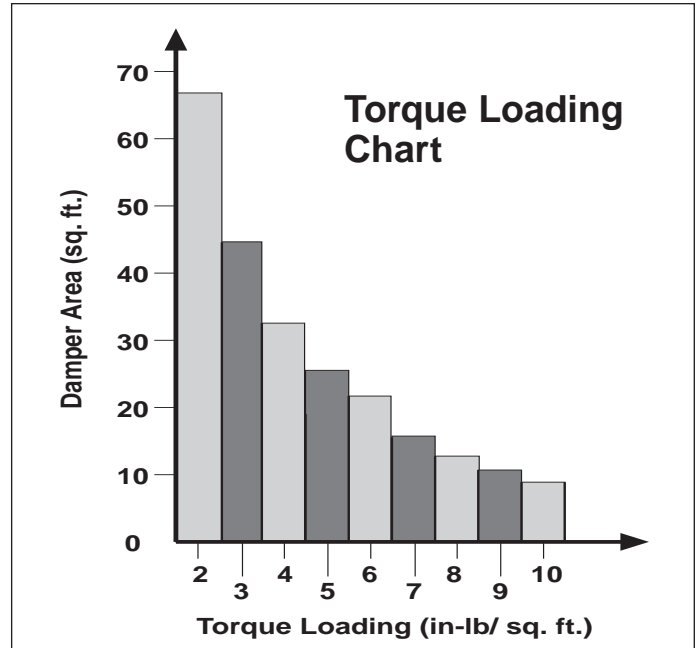

General Information

Belimo actuators should be mounted indoors in a dry, relatively clean environment free from corrosive fumes. If the actuator is to be mounted outdoors, a protective enclosure must be used to shield the actuator.

For new construction work, **order dampers with extended shafts**. Instruct the installing contractor to allow space for mounting and service of the Belimo actuator on the shaft. The damper shaft must extend at least 3 1/2" from the duct. If the shaft extends less than 3-1/2" or if an obstruction blocks access, the shaft can be extended with the AV 10-18 shaft extension accessory or the actuator may be mounted in its short shaft configuration.

Mechanical Operation

The actuator is mounted directly to a damper shaft up to 1.05" in diameter by means of its universal clamp. A crankarm and several mounting brackets are available for applications where the actuator cannot be direct coupled to the damper shaft. The AF series actuators provide true spring return operation for reliable fail-safe application and positive close-off on air tight dampers. The spring return system provides constant torque to the damper with, and without, power applied to the actuator. The AF...-S versions are provided with 2 built-in auxiliary switches. These SPDT switches are provided for safety interfacing or signaling, for example, for fan start-up. The switching function at the fail-safe position is fixed at +5°, the other switch function is adjustable between +25 to +85°.

Automatic Airtight Dampers/Manual Override

The AF series provides 95° of rotation and is provided with a graduated position indicator showing 0° to 95°. The AF has a unique manual positioning mechanism which allows the setting of any damper position within its 95° of rotation. A pre-tensioned spring automatically tightens damper when power is applied to the actuator, compensating for damper seal deterioration. The actuator is shipped at +5° (5° from full fail-safe) to provide automatic compression against damper gaskets for tight shut-off. When power is applied, the manual mechanism is released and the actuator drives toward the full fail-safe position.

Standard Mounting

Note: The AF...series actuator is shipped with the manual override adjusted for a +5° position at the universal clamp (not at full fail-safe, 0°). This allows for automatic compression of damper blade seals when the actuator is in use, providing tight shut-off. This assumes that the damper is to have tight shut-off at the fail-safe position. If tight close-off is desired at the opposite direction from fail-safe, the manual override should be released so the actuator can go to the full fail-safe position. See the manual override instructions.

1. Manually move the damper to the fail-safe position (usually closed). If the shaft rotated counterclockwise (↺), this is a CCW installation. If the shaft rotated clockwise (↻), this is a CW installation. In a CCW installation, the actuator side marked "CCW" faces out, while in a CW installation, the side marked "CW" faces out. All other steps are identical.
2. The actuator is usually shipped with the universal clamp mounted to the "CCW" side of the actuator. To test for

Mechanical Installation

adequate shaft length, slide the actuator over the shaft with the side marked “CCW” (or the “CW” side if this is the side with the clamp). If the shaft extends at least 1/8” through the clamp, mount the actuator as follows. If not, go to the *Short Shaft Installation* section.

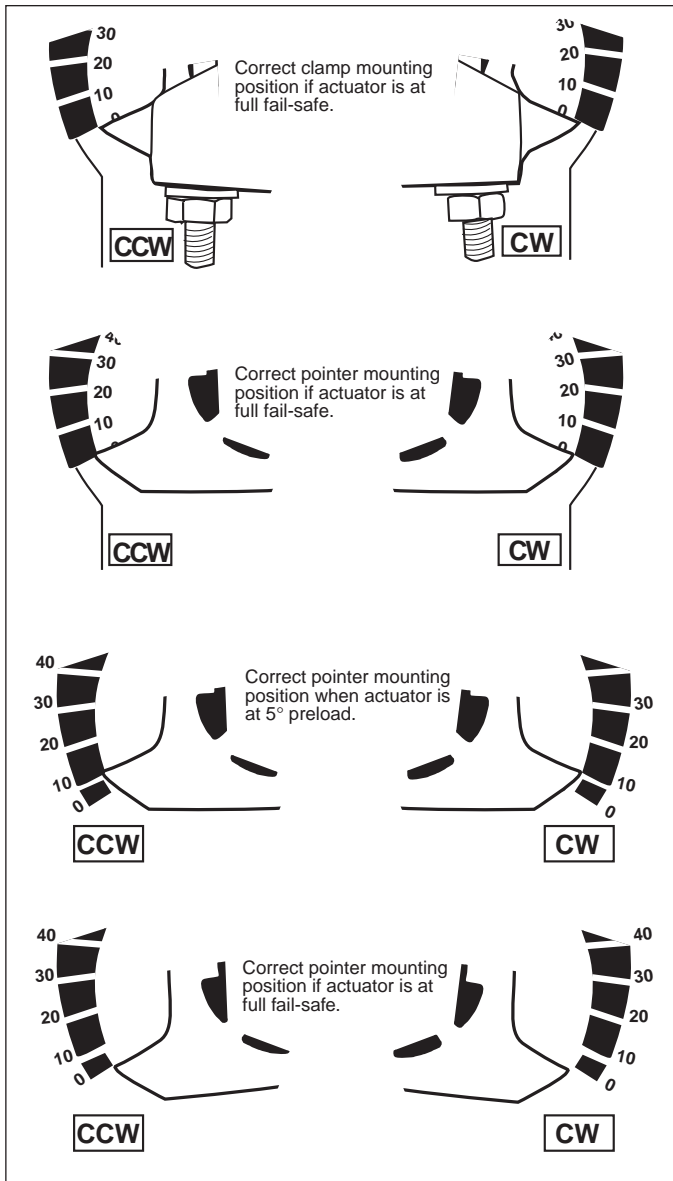

Fig. A Universal Clamp and IND-AF2 Pointer (optional) positions indicating fail-safe and pre-load settings

- If the clamp is not on the correct side as determined in step #1, re-mount the clamp as follows. If it is on the correct side, proceed to step #5. Look at the universal clamp. If you are mounting the actuator with the “CCW” side out, position the clamp so that the pointer section of the tab is pointing to 0° (see Fig. C) and the spline pattern of the clamp mates with spline of the actuator. Slip the clamp over the spline. (Use the same procedure if the “CW” side is out.) If your application requires a mechanical minimum position, read the *Rotation Limiting, Mechanical Minimum Damper Position* section.

- Lock the clamp to the actuator using the retaining clip.
- Verify that the damper is still in its full fail-safe position.
- Slide the actuator over the shaft.
- Position the actuator in the desired location.
- Tighten the two nuts on the clamp using a 10mm wrench or socket using 6-8 ft-lb of torque.
- Slip the stud of the anti rotation strap into the slot at the base of the actuator. The stud should be positioned approximately 1/16 of an inch from the closed end of the slot. Bend the strap as needed to reach the duct. Attach the strap to the duct with #8 self tapping screws.

Short Shaft Installation

If the shaft extends at least 3/4” from the duct, follow these steps:

- Determine the best orientation for the universal clamp on the back of the actuator. The best location would be where you have the easiest access to the V bolt nuts on the clamp.
- Engage the clamp to the actuator as close as possible to the determined location.
- Lock the clamp in place using the remaining retainer clip.
- Verify that the damper is still in its full fail-safe position.
- Slide the actuator over the shaft.
- Position the actuator in the desired location.
- Tighten the two nuts on the clamp using a 10mm wrench or socket using 6-8 ft-lb of torque.
- Slip the stud of the anti-rotation strap into the slot at the base of the actuator. The stud should be positioned approximately 1/16 of an inch from the closed end of the slot. Bend the strap as needed to reach the duct. Attach the strap to the duct with #8 self tapping screws.
- If damper position indication is required, use the optional IND-AF2 pointer. See Fig. A.

Jackshaft Installation

The AF... series actuator is designed for use with jackshafts up to 1.05” in diameter. In most applications, the AF actuator may be mounted in the same manner as a standard damper shaft application. If more torque is required than one AF actuator can provide, a second AF actuator may be mounted to the jackshaft using the ZG-102 multiple actuator mounting bracket. **See wiring guide for wiring details.**

AF actuators which may be used on one shaft:	
Model	Max Quantity Per Shaft
AF24 (-S) US	4
AF120 (-S) US	
AF230 (-S) US	
AF24-SR US	4
AF24-MFT (-S) US	4

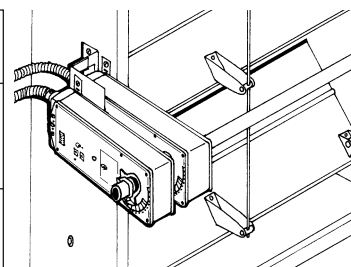

Mounting:

If the actuators are mounted on the opposed ends of the shaft, the actuator direction must be selected carefully. Usually, the direction of rotation is reversed.

Multiple Actuator Mounting

If more torque is required than one AF actuator can provide, a second AF actuator may be mounted to the shaft using the ZG-102 multiple mounting bracket.

Notes: The manual positioning mechanism cannot be used in multiple actuator applications.

Special Wiring and Additional Information: See wiring guide

Rotation Limitation

The angle of rotation limiter, ZDB-AF2, is used in conjunction with the tab on the universal clamp or IND-AF2 position indicator which comes with the ZDB-AF2. In order to function properly, the clamp or indicator must be mounted correctly. See Fig. A.

The ZDB-AF2 may not work in certain mounting orientations using the ZG-106 or ZG-107 mounting brackets. It will not work with the ZG-108 mounting bracket. Limiting the damper rotation must be accomplished by adjusting the crankarm linkage.

The ZDB-AF2 may be used in 2 ways to control the rotational output of the AF series actuator. One use is in the application where a damper has a designed rotation less than 90°. An example would be a 45° or 60° rotating damper. The other application would be to set a minimum damper position which can be easily set or changed without having to remove the actuator from the damper.

Damper rotation limiting

1. Determine the amount of damper rotation required.
2. Locate the Angle of Rotation Limiter (ZDB-AF2) on the actuator so that its edge lines up with the degree graduation on the actuator face which corresponds with the required rotation. See Fig. C.

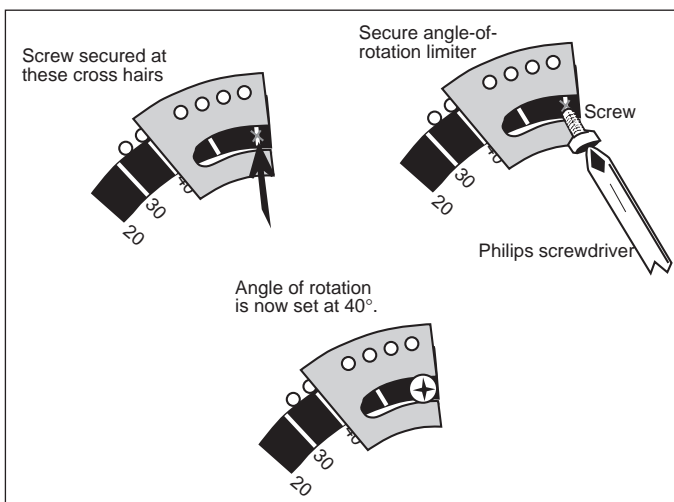

Fig. C ZDB-AF2 Securing the Angle of Rotation Limiter

3. Find the appropriate cross-hair location through the slot of the limiter. This is the screw mounting location.
4. Pierce through the label material to allow easy fastening of the retaining screw.
5. Position the limiter back to the desired position, making sure the locating “teeth” on the limiter are engaged into the locating holes on the actuator.

6. Fasten the limiter to the actuator using the self tapping screw provided.
7. Test the damper rotation either manually with the manual crank or apply power and if required, a control signal. Re-adjust if necessary.

Mechanical minimum damper position

In order to use this procedure, the actuator must be mounted for short shaft mounting. See pages 8 & 10.

1. Position the damper to its minimum position by using the manual crank or by providing the appropriate control signal to the AF24... modulating type actuator.
2. Place the indicator on to the actuator spline in the approximate position shown in Fig. D. Fasten it with the retaining clip. Note that the mounting orientation is different than the mounting used for *Damper Rotation Limiting*.

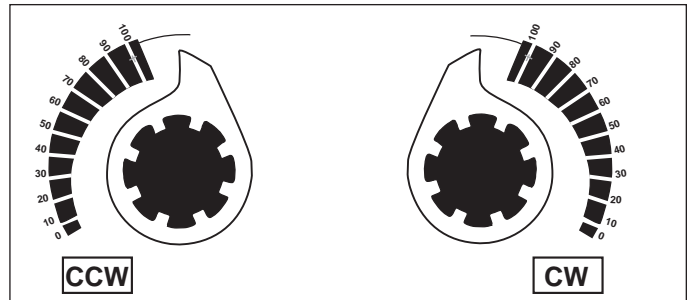

Fig. D

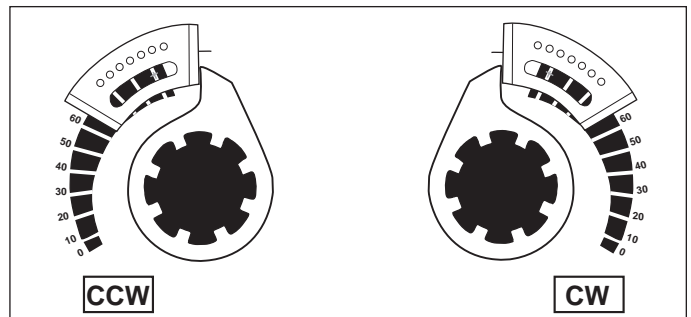

Fig. E

3. Place the ZDB-AF2 rotation limiter on the actuator so that it either makes contact with, or is as close as possible to, the edge of the indicator. See Fig. E. Make sure that the locating teeth are engaged into the locating holes on the actuator. If all of the mounting teeth do not align with the holes, the mounting location of the indicator to the spline may have to be moved. The limiter would then be remounted to get the best position match of both parts.
4. Find the cross-hair location through the slot of the limiter. This is the screw mounting location.
5. Pierce through the label material to allow easy fastening of the retaining screw.
6. Fasten the limiter to the actuator using the self tapping screw provided.
7. Test the damper operation either manually with the manual crank or apply power and if required, a control signal. Re-adjust if necessary.

This method should not be used for outside air damper applications. The damper will never go to the full close-off position. This may cause coils to freeze or other system problems. The AF24-SR (-S) US wired to either the SGA24 or SGF24 can be used for minimum position setting and still provide full close-off.

Manual override

The AF series actuators can be manually positioned to ease installation or for emergency positioning.

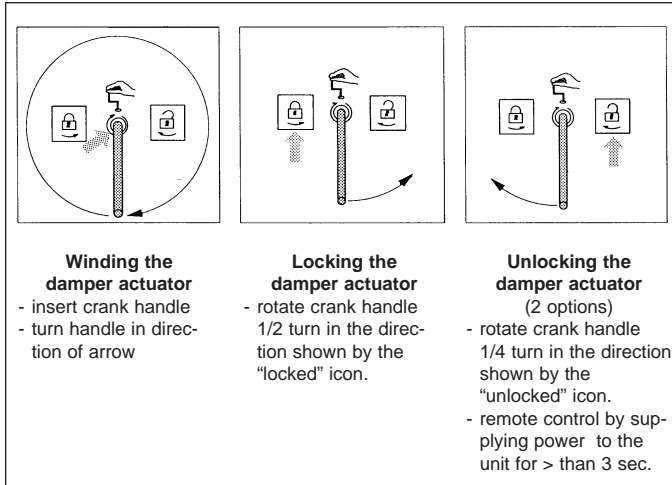

- The manual override will only work if no power is available to the actuator.
- Insert the manual crank (shipped with the actuator) into the hexagon hole located on either side of the actuator. An illustration, located on the label, shows the location.
- Turn the crank in the direction shown on the label (clockwise on the "CW" side, counterclockwise on the "CCW" side). It will take approximately 19 revolutions to rotate the full 95° of rotation.
- To lock the actuator in the required position, rotate the crank quickly in the opposite direction, 1/2 of a revolution. The "lock closed" icon on the label shows the correct direction.
- The manual override may be disengaged in 2 ways.
 - Rotate the crank about a 1/4 revolution in the same direction as the initial winding. The "lock open" icon shows the correct direction.
 - Apply power to wire 1 and 2. The actuator will automatically disengage the override function and will go to the "on" position in the case of the on-off versions. Or, in the case of the proportional versions, go to the 0 signal position and then go to the position corresponding to the control signal. The actuator will now work normally.

Testing the installation without power

The actuator/damper installation may be tested without power at the actuator. Refer to the manual positioning section of the instructions. Move the damper to its full non-fail-safe position using the manual crank. Disengage the manual position mechanism and have the damper go to full fail-safe position. Correct any mechanical problems and retest.

Auxiliary Switches

The AF series actuators may be ordered with 2 built-in SPDT auxiliary switches used for safety interfacing or signalling, for example, for fan start-up. The switch position near the fail-safe position is fixed at 5°. The other is adjustable between 25 and 85° of rotation. The crank, supplied with the actuator, or a 3mm allen wrench is used to adjust the switching position.

Switch Rating

Voltage	Resistive Load	Inductive Load
120 VAC	7A	5A
250 VAC	7A	2.5A

Two methods may be used to adjust the switching point of the adjustable switch.

Method 1 - See Fig. F

- The actuator must be in its fail-safe position.
- Insert the crank into the hexagon shaped hole located in the center of the adjustable switch pointer.
- Rotate the crank until the switch pointer is at the desired switch point in degrees as shown.

Method 2 - See Fig. G

- Position the damper to the point at which you want the switch to activate. This may be done by using the manual override or by providing the appropriate proportional signal to AF24... modulating type actuator. The position of the switch pointer is not important during this step.
- Insert the crank into the hexagon shaped hole located in the center of the adjustable switch pointer.
- Rotate the switch pointer to just past the switch point indicating arrow as shown.

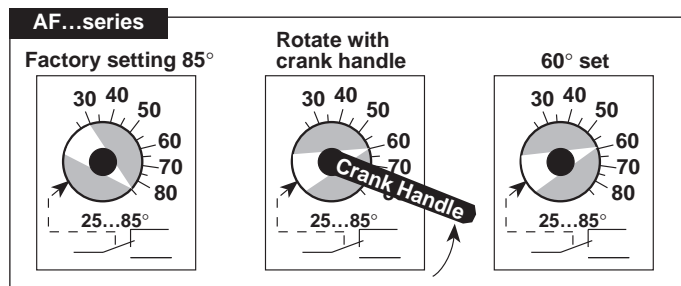

Fig. F

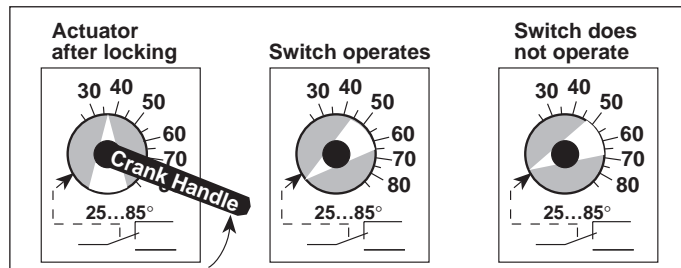

Fig. G

Non-direct mounting methods



KH-AF crankarm including retaining ring. *Caution:* the retaining clip supplied with the clamp is **not** used to mount the KH-AF crankarm.

The KH-AF (-1) crankarm is used in non-direct coupled mounting applications. The KH-AF (-1) may also be used to simultaneously direct couple to a damper shaft and provide an additional crank arm connection to a second damper. The KH-AFV V-bolt kit must be used for this non-direct application (see illustration below).

Two sizes are available:

- KH-AF For round shafts up to 3/4" or square shafts up to 5/8"
- KH-AF-1 For jackshafts up to 1.05"

KH-AFV V-bolt kit for KH-AF(-1) crankarm

Note: KH-AF (-1) crankarms cannot be used on AF Series 1 actuators.

Dimensions (All numbers in brackets are in millimeters.)

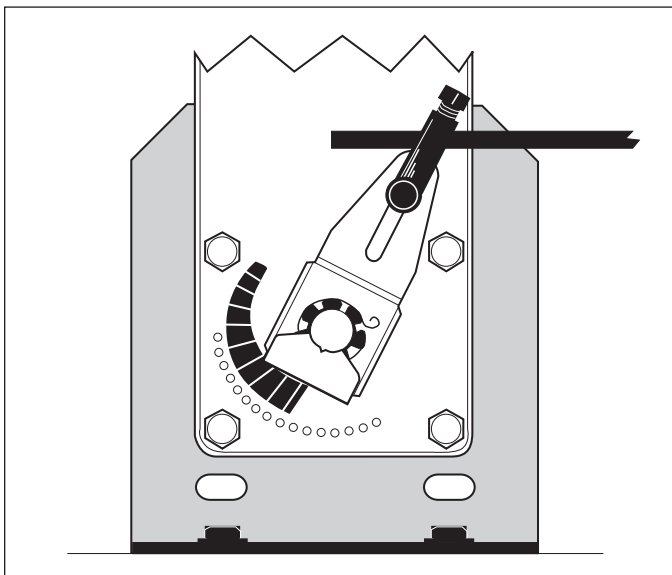
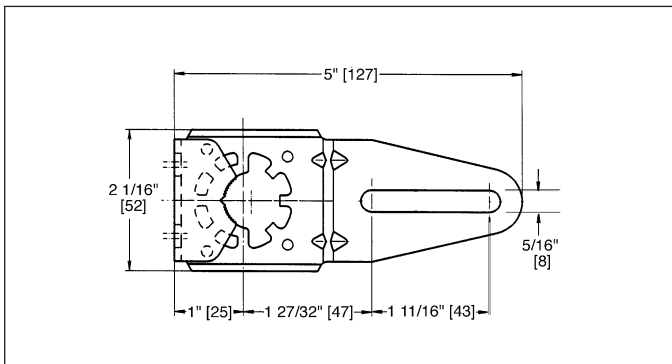

KH-AF Non-direct mounting with ZG-108 mounting bracket

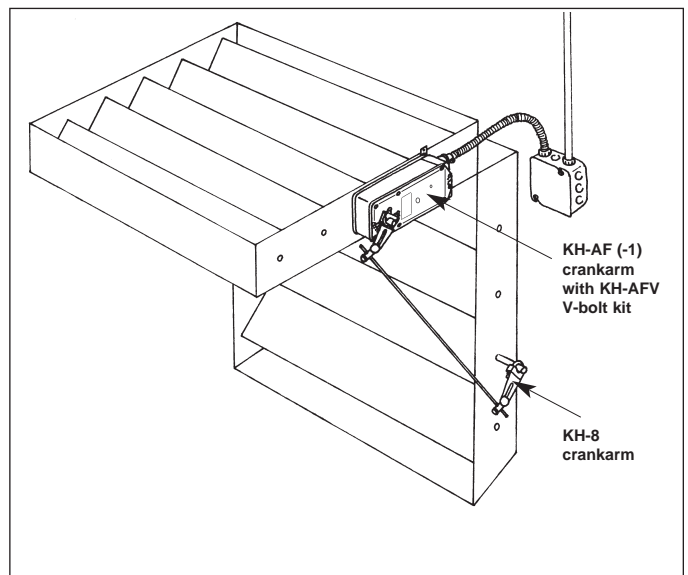

Multiple dampers direct coupled to one actuator with linkage to operate the other damper.

Electrical Operation

General

The AF series actuators utilize brushless DC motor technology. The AF uses this motor in conjunction with an Application Specific Integrated Circuit (ASIC). In the On-Off versions of the AF, the ASIC monitors and controls the actuator's rotation and a digital rotation sensing function to prevent damage to the actuator. The AF24... modulating type actuators incorporate a built in microprocessor. The microprocessor provides the intelligence to the ASIC to provide a constant rotation rate and knows the actuator's exact zero position.

Brushless DC motor operation

Belimo's brushless DC motor spins by reversing the poles of stationary electromagnets housed inside of a rotating permanent magnet. The electromagnetic poles are switched by a special ASIC circuit developed by Belimo. Unlike the conventional DC motor, there are no brushes to wear or commutators to foul.

Overload protection

The AF series actuators are protected from overload at all angles of rotation. The ASIC circuit constantly monitors the rotation of the DC motor inside the actuator and stops the pulses to the motor when it senses a stall condition. The DC motor remains energized and produces full rated torque to the load. This helps ensure that dampers are fully closed and that edge and blade seals are always properly compressed.

Motor position detection

Belimo brushless DC motors eliminate the need for potentiometers for positioning in modulating type actuators. Inside the motor are three "Hall Effect" sensors. These sensors detect the spinning rotor and send pulses to the microprocessor which counts the pulses and calculates the position to within 1/3 of a revolution of the motor.

Control Accuracy and Stability

AF24-SR US actuators have built-in brushless DC motors which provide better accuracy and longer service life.

The AF24-SR US actuators are designed with a unique non-symmetrical deadband. The actuator follows an increasing or decreasing control signal with a 50 mV resolution. If the signal changes in the opposite direction, the actuator will not respond until the control signal changes by 50 mV. This allows these actuators to track even the slightest deviation very accurately, yet allowing the actuator to "wait" for a much larger change in control signal due to control signal instability.

AF Actuator responds to a 50 mV signal when not changing direction from stop

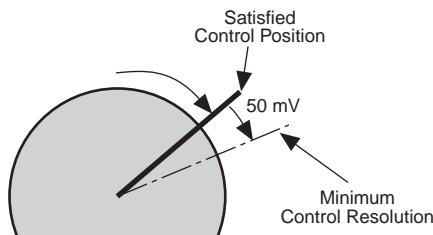

AF Actuator responds to a 50 mV signal when reversing direction from stop position.

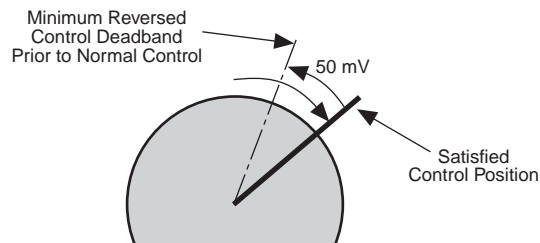

The AF24-MFT US control accuracy and stability can be found in the MFT specifications, page 187.

General Wiring Instructions

WARNING The wiring technician must be trained and experienced with electronic circuits. Disconnect power supply before attempting any wiring connections or changes. Make all connections in accordance with wiring diagrams and follow all applicable local and national codes. Provide disconnect and overload protection as required. Use copper, twisted pair, conductors only. If using electrical conduit, the attachment to the actuator must be made with flexible conduit.

Always read the controller manufacturer's installation literature carefully before making any connections. Follow all instructions in this literature. If you have any questions, contact the controller manufacturer and/or Belimo.

Transformer(s)

The AF24 . . actuators require a 24 VAC class 2 transformer and draws a maximum of 10 VA per actuator. The actuator enclosure cannot be opened in the field, there are no parts or components to be replaced or repaired.

- EMC directive: 89/336/EEC
- Software class A: Mode of operation type 1
- Low voltage directive: 73/23/EEC

CAUTION: It is good practice to power electronic or digital controllers from a separate power transformer than that used for actuators or other end devices. The power supply design in our actuators and other end devices use half wave rectification. Some controllers use full wave rectification. When these two different types of power supplies are connected to the same power transformer and the DC commons are connected together, a short circuit is created across one of the diodes in the full wave power supply, damaging the controller. Only use a single power transformer to power the controller and actuator if you know the controller power supply uses half wave rectification.

Multiple actuators, one transformer

Multiple actuators may be powered from one transformer provided the following rules are followed:

1. The TOTAL current draw of the actuators (VA rating) is less than or equal to the rating of the transformer.
2. Polarity on the secondary of the transformer is strictly followed. *This means that all No. 1 wires from all actuators are connected to the common leg on the transformer and all No. 2 wires from all actuators are connected to the hotleg. Mixing wire No. 1 & 2 on one leg of the transformer will result in erratic operation or failure of the actuator and/or controls.*

Multiple actuators, multiple transformers

Multiple actuators positioned by the same control signal may be powered from multiple transformers provided the following rules are followed:

1. The transformers are properly sized.
2. All No. 1 wires from all actuators are tied together and tied to the negative leg of the control signal. See wiring diagram.

Wire length for AF... actuators

Keep power wire runs below the lengths listed in the Fig. H. If more than one actuator is powered from the same wire run, divide the allowable wire length by the number of actuators to determine the maximum run to any single actuator.

Example: 3 actuators, 16 Ga wire
 $350 \text{ Ft} \div 3 \text{ Actuators} = 117 \text{ Ft.}$ Maximum wire run

Maximum wire length:

Wire Size	Max. Feet.		Wire Size	Max. Feet
12 Ga	900 Ft.		18 Ga	225 Ft.
14 Ga	550 Ft.		20 Ga	125 Ft.
16 Ga	350 Ft.		22 Ga	60 Ft.

Fig. H

Wire Type and Wire Installation Tips

For most installations, 18 or 16 Ga. cable works well with the AF24 . . actuators. Use code-approved wire nuts, terminal strips or solderless connectors where wires are joined. It is good practice to run control wires unspliced from the actuator to the controller. If splices are unavoidable, make sure the splice can be reached for possible maintenance. Tape and/or wire-tie the splice to reduce the possibility of the splice being inadvertently pulled apart.

The AF24... proportional actuators have a digital circuit that is designed to ignore most unwanted input signals (pickup). In some situations the pickup may be severe enough to cause erratic running of the actuator. For example, a large inductive load (high voltage AC wires, motors, etc.) running near the power or control wiring may cause excessive pickup. To solve this problem, make one or more of the following changes:

1. Run the wire in metallic conduit.
2. Re-route the wiring away from the source of pickup.
3. Use shielded wire (Belden 8760 or equal). **Ground the shield to an earth ground. Do not connect it to the actuator common.**

Initialization of the AF24-SR US, and AF24-MFT US

When power is initially applied, the actuator will first release its manual preload position (This assumes a manual position has been set). The actuator will then rotate to the full fail-safe position. At this point the microprocessor recognizes that the actuator is at full fail-safe and uses this position as the base for all of its position calculations. The microprocessor will retain the initialized zero during short power failures of up to 20 seconds. The AF24-MFT US will also return to its position prior to the 20-second-or-less power loss. For power failures greater than 20 seconds, the actuator would naturally return to its full fail-safe position prior to the microprocessor losing its memory. The actuator will also re-initialize if the manual position mechanism is used.

Startup and Checkout



Instructions For AF24-SR US and AF24-MFT US + P-100...

AF24-SR US and AF24-MFT US + P-100... Electrical check-out procedure

Step	Procedure	Expected Response	Gives Expected Response Go To Step...	Does Not Give Expected Response Go To Step...
1.	Control signal is applied to actuator.	Actuator will move to its "Control Signal" position.	Actuator operates properly Step 7	No response at all Step 2 Operation is reversed Step 3 Does not drive toward "Control Signal Position" Step 4
2.	Check power wiring. Correct any problems. See Note 1.	Power supply rating should be \geq the total power requirement of the actuator(s). Minimum voltage of 19.2 VAC or 21.6 VDC.	Power wiring corrected, actuator begins to drive Step 1	Power wiring corrected, actuator still does not drive Step 4
3.	Turn reversing switch to the correct position. Make sure the switch is turned all the way left or right.	Actuator will move to its "Control Signal" position.	Actuator operates properly. Step 7	Does not drive toward "Control Signal Position" Step 4
4.	Make sure the control signal positive (+) is connected to Wire No 3 and control signal negative (-) is connected to wire No. 1. Most control problems are caused by reversing these two wires. Verify that the reversing switch is all the way CCW or CW.	Drives to "Control Signal" position	Actuator operates properly. Step 7	Step 5
5.	Check input signal with a digital volt meter (DVM). Make sure the input is within the range of the actuator. For AF24-SR US this is 2 to 10 VDC or 4 to 20 mA. Note: The input signal must be above the 2 VDC or 4 mA to have the actuator move.	Input voltage or current should be $\pm 1\%$ of what controller's adjustment or programming indicate.	Controller output (actuator input) is correct. Input Polarity Correct. Step 6	Reprogram, adjust repair or replace controller as needed. Step 1
7.	Check damper torque requirement.	Torque requirement is \leq actuator's minimum torque.	Defective Actuator. Replace Actuator - See Note 2	Recalculate actuator requirement and correct installation.
8.	Actuator works properly. Test controller by following controller manufacturer's instructions.			

- Note 1** Check that the transformer(s) are sized properly.
- If a common transformer is used, make sure that polarity is observed on the secondary. This means connect all No. 1 wires to one leg of the transformer and all No. 2 wires to the other leg of the transformer.
 - If multiple transformers are used with one control signal, make sure all No. 1 wires are tied together and tied to control signal negative (-).
 - Controllers and actuators must have separate 24 VAC/VDC power sources.
- Note 2** If failure occurs within 5 years from original installation date, notify Belimo and give details of the application.